

UNI 2

User manual

Instructions for use and maintenance



© | Aerservice Equipments S.r.l.
2021 all rights reserved

Reproduction of this manual, total or partial, is forbidden

Index

| | |
|---|----|
| 1. GENERAL INFORMATION | 3 |
| 1.1. Introduction..... | 3 |
| 1.2. Information on copyright and related rights..... | 3 |
| 1.3. Instructions for the user | 3 |
| 2. SAFETY | 4 |
| 2.1. General information | 4 |
| 2.2. Warnings and symbols in the user manual | 4 |
| 2.3. Signs applied by the user..... | 4 |
| 2.4. Safety warnings for the operator | 5 |
| 2.5. Safety warnings for maintenance and troubleshooting..... | 5 |
| 2.6. Warning about specific dangers | 6 |
| 3. UNIT DESCRIPTION | 7 |
| 3.1. Purpose..... | 7 |
| 3.2. Features and versions..... | 8 |
| 3.3. Proper use | 8 |
| 3.4. Improper use of the unit | 9 |
| 3.5. Marks and labels on the unit | 10 |
| 3.6. Residual risk..... | 11 |
| 4. TRANSPORT AND STORAGE | 11 |
| 4.1. Transport | 11 |
| 4.2. Storage..... | 11 |
| 5. ASSEMBLY | 12 |
| 5.1. Unpacking and castors assembling..... | 12 |
| 5.2. Assembling the extraction arm | 13 |
| 5.3. Active carbons filter (optional)..... | 14 |
| 6. USE..... | 14 |
| 6.1. User qualification..... | 14 |
| 6.2. Control panel | 15 |
| 6.3. Correct positioning of the capture hood | 16 |
| 6.4. Start of the unit | 17 |
| 6.5. Start of the unit with automatic START-STOP device..... | 17 |
| 7. REGULAR MAINTENANCE | 19 |
| 7.1. CARE..... | 19 |
| 7.2. Ordinary maintenance..... | 20 |
| 7.3. Replacement of filters | 20 |
| 7.4. Digital control panel: alarms and alarm reset | 26 |

| | | |
|--------|--|----|
| 7.5. | Troubleshooting | 28 |
| 7.6. | Emergency measures..... | 29 |
| 8. | DISPOSAL | 29 |
| 8.1. | Plastics | 29 |
| 8.2. | Metals..... | 29 |
| 8.3. | Filter media..... | 29 |
| 8.4. | Waste liquids | 29 |
| 9. | ATTACHMENTS | 30 |
| 9.1.1. | UNI 2 H Technical data | 30 |
| 9.1.2. | UNI 2 E Technical data..... | 31 |
| 9.1.3. | UNI 2 C Technical data..... | 32 |
| 9.1.4. | UNI 2 C – W3 / UNI 2 C – W3 Laser Technical data | 33 |
| 9.1.5. | UNI 2 K Technical data..... | 34 |
| 9.2. | Spare parts and accessories | 35 |
| 9.3.1. | EC declaration of conformity..... | 36 |
| 9.3.2. | UK Declaration of Conformity (UKCA) | 37 |
| 9.4. | Dimensional drawing..... | 38 |
| 9.5.1. | Wiring diagram UNI 2 H/K 230V 1ph..... | 39 |
| 9.5.2. | Wiring diagram UNI 2 H/K 400V 3ph..... | 39 |
| 9.5.3. | Wiring diagram UNI 2 E 230V 1ph..... | 40 |
| 9.5.4. | Wiring diagram UNI 2 E 400V 3ph..... | 40 |
| 9.5.5. | Wiring diagram UNI 2 C 230V 1ph..... | 41 |
| 9.5.6. | Wiring diagram UNI 2 C 400V 3ph..... | 41 |
| 9.5.7. | Wiring diagram UNI 2 C-W3 / UNI 2 C-W3 Laser 230V 1ph..... | 42 |
| 9.5.8. | Wiring diagram UNI 2 C-W3 / UNI 2 C-W3 Laser 400V 3ph..... | 42 |

1. GENERAL INFORMATION

1.1. Introduction

This user manual provides important information for the correct and safe operation of Aerservice Equipments' mobile filter unit UNI 2 suitable for extraction of welding fumes.

The instructions contained in this manual help to avoid dangers, to reduce repair costs and machine downtime and to increase the reliability and lifetime of the unit.

The user manual shall always be at hand; all information and warnings contained therein shall be read, observed and followed by all people who work by the unit and are involved in tasks, such as:

- transport and assembly;
- normal use of the unit during work;
- maintenance (replacement of filters, troubleshooting);
- disposal of the unit and its components.

1.2. Information on copyright and related rights

All information included in this instruction manual must be treated confidentially and may be made available and accessible only to authorized people.

It may be disclosed to third parties only with the prior written consent of Aerservice Equipments.

All documentation is protected under the copyright law.

Any reproduction, total or partial, of this document, as well as its use or transmission without prior and explicit authorization by Aerservice Equipments, is prohibited.

Any violation of this prohibition is punishable by law and involves penalties.

All rights relating to industrial property rights are reserved to Aerservice Equipments.

1.3. Instructions for the user

These Instructions are an integral part of the unit UNI 2.

The user must ensure that all personnel in charge of the unit have adequate knowledge of these Instructions.

The user is required to complete the Manual with instructions based on national regulations for injury prevention and environmental protection, including information on surveillance and notification obligations, in order to consider specific requirements, such as organization of work, working methods and personnel involved.

In addition to the instructions and regulations for the prevention of accidents, in force in the country and in the place where the unit is used, it is necessary to comply with the common technical principles for a safe and correct use of the unit.

The user shall not make any modifications to the unit, nor add parts or adjust it without permission by Aerservice Equipments because this could jeopardize its safety!

The spare parts used shall correspond to the technical specs established by Aerservice Equipments.

Always use original spare parts to ensure correspondence of the unit to the technical specifications.

Allow only trained and expert personnel for the operation, maintenance, repair and transport of the unit.

Establish individual responsibilities for operation, configuration, maintenance and repair.

2. SAFETY

2.1. General information

The unit was developed and manufactured using the latest technology and in accordance with the general workplace safety guidelines.

However, the use of the unit could present risks for the operator or risks of damage to the unit and other objects:

- If the personnel in charge has not received instructions or training;
- In case of use that is not in accordance with the intended purpose;
- In case of maintenance that is not carried out as indicated in this manual.

2.2. Warnings and symbols in the user manual



DANGER

This warning indicates an imminent dangerous situation.
Not respecting it can result in death or serious injury.



WARNING

This warning indicates a possible dangerous situation.
Not respecting it can result in death or serious injury.



WARNING

This warning indicates a possible dangerous situation.
Not respecting it can result in minor injury or material damage.



INFO

This warning provides useful information for safe and proper use.

- The point in bold marks the work and / or operating procedure.
The procedures need be performed in sequence.
- Any list is marked with a horizontal dash.

2.3. Signs applied by the user

The user is responsible for the application of signs on the unit or in the near area.

Such signs may concern, for example, the obligation to wear personal protective equipment (PPE).

Refer to the local regulations for advice.

2.4. Safety warnings for the operator

Before using the unit, the operator in charge must be suitably informed and trained for the use of the unit and the relevant materials and means.

The unit must only be used in perfect technical condition and in compliance with the intended purposes, the safety standards and the warnings relating to dangers as reported in this Manual.

All failures, especially those that can jeopardize safety, shall be removed immediately!

Each person responsible for commissioning, use or maintenance of the unit must be familiar with these instructions and must have understood their content, especially paragraph 2 Safety.

It is not enough to read the manual for the first time when you are already working.

This is especially true for people who work on the unit only occasionally.

The manual shall always be available near the unit.

No liability is accepted for damage or injury due to failure to comply with these instructions.

Observe the current workplace precaution rules, as well as other general and standard technical safety and hygiene tips.

Individual responsibilities for the various maintenance and repair operations must be clearly established and respected. Only in this way malfunctions can be avoided - especially in dangerous situations.

The user shall ensure that the personnel responsible for use and maintenance of the unit shall wear personal protective equipment (PPE). These are mainly safety shoes, goggles and protective gloves.

Operators must not wear long loose hair, baggy clothing or jewelry! There is a risk of being trapped or drawn in by the moving parts of the unit!

In case of any changes on the unit, that may affect safety, switch off the equipment immediately, secure it and report the incident to the department / person in charge!

Interventions on the unit can only be carried out by competent, reliable and trained personnel.

Personnel undergoing training or in a training program may only be permitted to work on the unit under the constant supervision of a trained person.

2.5. Safety warnings for maintenance and troubleshooting

For all maintenance and troubleshooting, ensure to use suitable personal protective equipment.

Before proceeding with any maintenance work, clean the unit.

An industrial vacuum cleaner with H efficiency class for dust can be helpful.

The preparation, maintenance and repair operations, as well as the detection of faults can only be carried out if the unit is without power supply:

- Remove the plug from the mains supply.

All screws that were loosened during maintenance and repair work need always be fastened again!

If so foreseen, the screws must be tightened with a torque wrench.

Before proceeding with maintenance and repairs it is necessary to remove all impurities, especially on the parts fastened with screws.

2.6. Warning about specific dangers



DANGER

All work on the electrical device of the unit shall be carried out exclusively by a qualified electrician or by personnel with the necessary training, under the direction and supervision of a qualified electrician and in accordance with the relevant safety standards.

Before any activity on the unit, it is necessary to disconnect the electric plug from the mains supply, to prevent accidental restarting.

Use only original fuses with the prescribed current limit.

All electrical components to be inspected, maintained and repaired must be disconnected. Block the devices used to disconnect the voltage, in order to avoid accidental or automatic restart.

First check the absence of voltage on the electric components, then isolate the adjacent components. During repairs, be careful not to modify the factory parameters so as not to jeopardize safety.

Check the cables regularly and replace in case of damage.



WARNING

Skin contact with welding powders etc. can cause irritation to sensitive people.

Repair and maintenance of the unit must only be carried out by qualified and authorized personnel, in compliance with safety requirements and accident prevention regulations in force.

Danger of serious damages to respiratory system.

To prevent contact with dust and inhalation, use protective clothing and gloves and an assisted ventilation device to protect the respiratory tissue.

During repairs and maintenance interventions, avoid diffusion of dangerous dust, in order to prevent health damage even of people not directly affected.



WARNING

The unit can produce noise emissions, specified in detail in the technical data.

If used with other machinery or due to the characteristics of the place of use, the unit may generate a higher sound level.

In this case, the person in charge is required to provide the operators with adequate protective equipment.

3. UNIT DESCRIPTION

3.1. Purpose

The unit is a compact mobile device suitable for filtration of welding fumes extracted directly at source, with a separation rate varying according to the model and the filtering section.

The unit can be equipped with an articulated arm and capture hood, or with a flexible hose.

The fumes (rich in polluting particulate) are purified through a multi-stage filtering section (which vary according to the model), before being released back in the workplace.

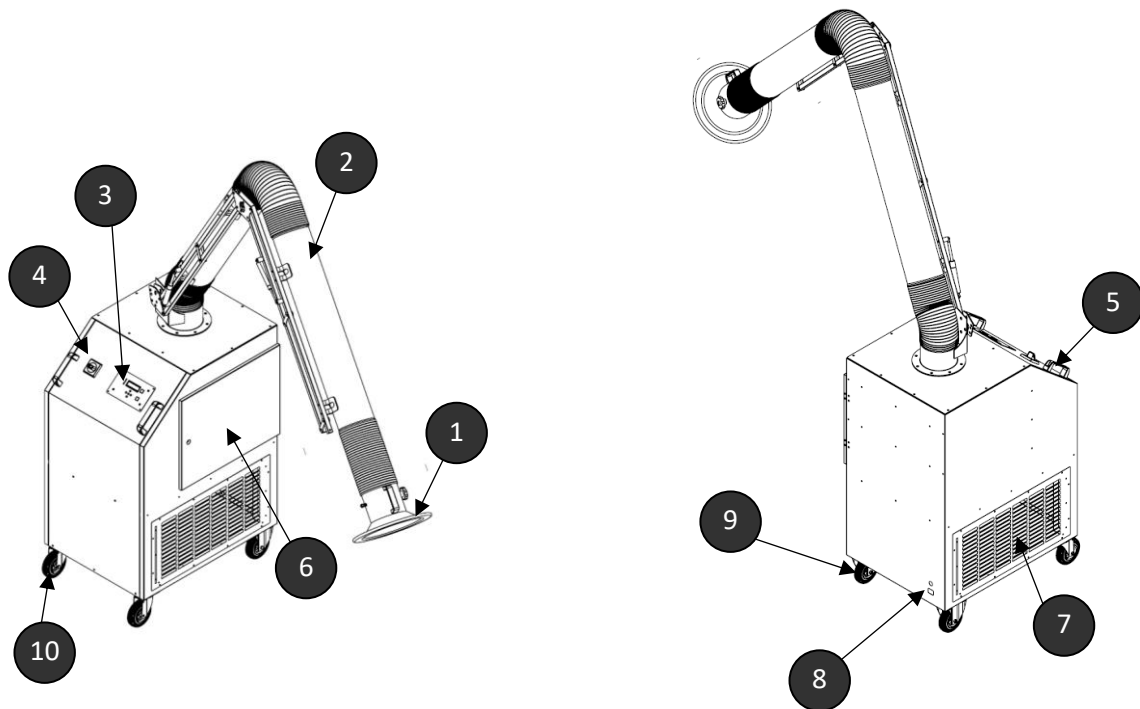



| Pos. | Description |
|------|-----------------|
| 1 | Capture hood |
| 2 | Articulated arm |
| 3 | Control panel |
| 4 | ON-OFF switch |
| 5 | Handles |

| Pos. | Description |
|------|--------------------------|
| 6 | Filter inspection door |
| 7 | Clean air expulsion grid |
| 8 | Panel socket |
| 9 | Fix wheels |
| 10 | Swivel wheels with brake |

3.2. Features and versions

The mobile air cleaner is available in four versions:

- **UNI 2 H**
with pocket filter - mechanical filtration
higher filter efficiency: 99,5% E12 (sec. UNI EN 1822:2019)
- **UNI 2 E**
with electrostatic filter
higher filter efficiency: ≥95% | A (sec. UNI 11254:2007) | E11 (sec. UNI EN 1822:2019)
- **UNI 2 C-W3**  **IFA**
with cartridge filter - mechanical filtration
higher filter efficiency: ≥99% | M (sec. DIN 660335-2-69)
machine efficiency: ≥99% | W3 (sec. UNI EN ISO 21904-1:2020 / UNI EN ISO 21904-2:2020)
- **UNI 2 C-W3 LASER**  **IFA**
with cartridge filter - mechanical filtration
higher filter efficiency: ≥99% | M (sec. DIN 660335-2-69)
Quantity of active carbons: 5Kg for SOV and 5Kg for acid and basic gazes
machine efficiency: ≥99% | W3 (sec. UNI EN ISO 21904-1:2020 / UNI EN ISO 21904-2:2020)
- **UNI 2 K**
with pockets filter - mechanical filtration and active carbons
higher filter efficiency: ISO ePM10 80% | (sec. UNI EN ISO 16890:2017) | M6 (sec. UNI EN 779:2012)
total quantity of active carbons: 12,1 kg

The version UNI 2 C certified by IFA institute is called UNI 2 C-W3.

This means that UNI 2 C-W3 conforms to the specifications set by IFA (Institut für Arbeitsschutz der Deutschen Gesetzlichen Unfallversicherung – Institute for Occupational Safety and Health of German Social Accident Insurance) and satisfies the relevant test requirements.

For the sake of transparency these requirements are evidenced in this manual with the relevant IFA logo:



The mobile unit UNI 2 C-W3 is provided with the DGUV mark and relevant W3 certificate (for welding fumes).

The position fo the label is indicated at par. 3.5 (symbols and labels on the unit UNI 2).
The specific version is indicated in the label and by IFA logo.

3.3. Proper use

The unit has been conceived to extract and filter the welding fumes generated by industrial welding processes, directly at source. In principle, the unit can be used in all work processes with emission of welding fumes. However, it is necessary to prevent the unit from sucking in "spark showers" from grinding or similar.

Pay attention to the dimensions and further data that are mentioned in the technical data sheet.

For the extraction of welding fumes containing carcinogenic substances, produced by the welding processes of alloy steels (such as stainless steel, zinc coated steel etc.), only those devices may be used according to current regulations that have been tested and approved for air recirculation.



INFO



The model UNI 2 C-W3 has been approved for extraction of fumes from welding processes with alloy steels and complies with W3 efficiency class requisites, according to international norms UNI EN ISO 21904-1:2020 and UNI EN ISO 21904-2:2020.



INFO

Carefully read and comply with the instructions in chapter “9.1 Technical data of the unit”. The use in accordance with the instructions of this manual also means following the specific instructions:

- for safety;
- for use and setting;
- for maintenance and repair,

mentioned in this user manual.

Any further or different use is to be considered as non-compliant.

The user of the unit is the sole responsible for any damage resulting from such non-compliant use.

This also applies to arbitrary interventions and unauthorized modifications on the unit.

3.4. Improper use of the unit

The unit is not suitable for use in hazardous areas falling under ATEX regulation.

Furthermore, the equipment should not be used in the following cases:

- Applications not corresponding to the intended purpose or not indicated for proper use of the unit and in which the air to be extracted:
 - contains sparks, for example from grinding, of a size and quantity such as to damage the suction arm and set fire to the filtering section;
 - contains liquids that may contaminate the air flow with vapors, aerosols and oils;
 - contains easily flammable dusts and / or substances that may cause explosive mixtures or atmospheres;
 - contains other aggressive or abrasive powders that may damage the unit and its filters;
 - contains organic and toxic substances / components (VOCs) which are released during the separation process. Only by inserting the active carbons filter (optional) the unit becomes suitable for filtration of these substances.
- The unit is not suited for installation in an outdoor area, where it may be exposed to atmospheric agents: the unit must be installed exclusively in closed and / or repaired buildings. Only a special version of the unit (with specific indications for outdoors) can be installed outside.

Any waste, such as for example collected particles, may contain harmful substances, therefore they must not be delivered to landfills for municipal waste. It is necessary to provide for an ecological disposal according to local regulations.



If the unit is used in accordance with its intended purpose, there is no reasonably foreseeable risk of improper use that might endanger health and safety of personnel.

3.5. Marks and labels on the unit

The unit has marks and labels which, if damaged or removed, need be immediately replaced with new ones in the same position.

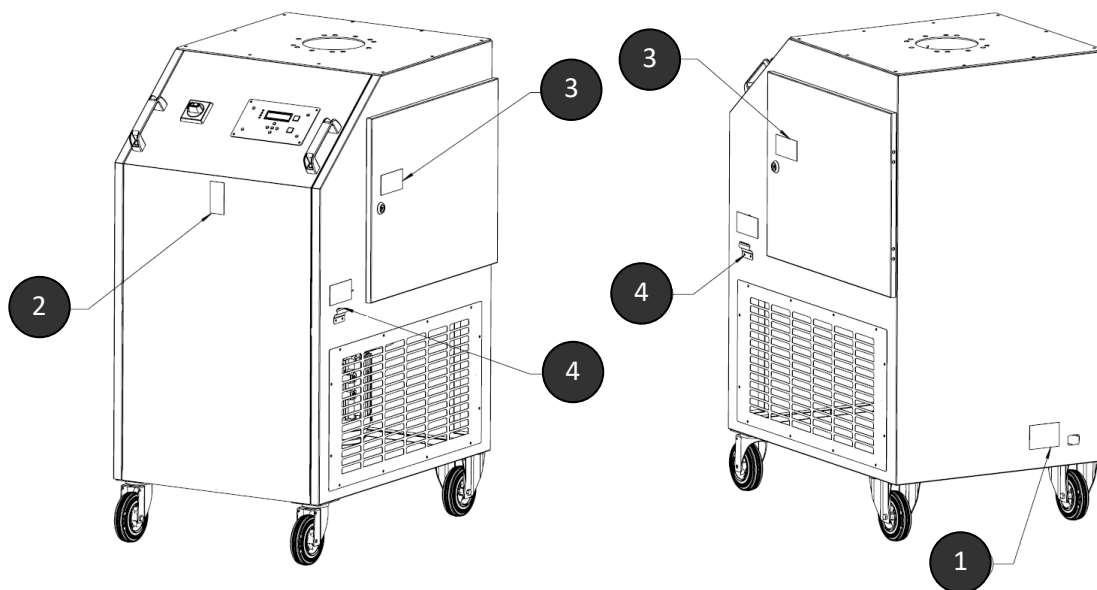
The user may have the obligation to place other marks and labels on the unit and in the surrounding area, e.g. referring to the local regulations for the use of personal protective equipment (PPE).



| Marks | Description | Position | Note |
|-----------|---|----------|---|
| Label [1] | Rating plate and CE mark | 1 | |
| Label [2] | DGUV test mark | 2 |  |
| Label [3] | W3 efficiency class for welding fumes according ISO 21904 | 3 |  |
| Label [4] | Instructions for the earth cable of the welding unit | 4 | Optional |

3.6. Residual risk

The use of the unit involves a residual risk as illustrated below, in spite of all safety measures. All users of the unit must be aware of the residual risk and follow the instructions to avoid any injury or damage.



WARNING

Risk of serious damage to the respiratory system - wear a protective device in class FFP2 or higher.
Skin contact with cutting fumes etc. can cause skin irritation in sensitive individuals. Wear protective clothing.
Before carrying out any welding job, make sure that the unit is positioned / installed correctly, that the filters are complete and intact and that the unit is active!
The unit can perform all its functions only when it has been switched on.
By replacing the various filters that make up the filtering section, the skin can come into contact with the separated powder and the processes carried out can volatilize this powder. It is necessary and mandatory to wear a mask and a protective suit.
Burning material sucked in and trapped in one of the filters, can cause smoldering. Switch off the unit, close the manual damper in the capture hood, and allow the unit to cool down in a controlled manner.

4. TRANSPORT AND STORAGE

4.1. Transport



DANGER

Danger of death from crushing during unloading and transport.
Improper maneuvers during lifting and transport can cause the pallet with the unit to overturn and fall.

- Never stand under suspended loads.

A transpallet or forklift truck are suitable for transporting any pallet with the unit. The weight of the unit is indicated on the rating plate.

4.2. Storage

The unit shall be stored in its original packaging at an ambient temperature between -20° C and +50° C in a dry and clean place.

The packaging must not be damaged by other objects.

For all units, the duration of storage is irrelevant.

5. ASSEMBLY



WARNING

Risk of serious injury when assembling the suction arm due to gas spring preload. A safety lock is provided on the metal articulating arm assembly.
Improper handling can lead to risk of abrupt displacement of the metal articulating arm assembly, resulting in severe injuries in the face or crushing of the fingers!



INFO

The user is required to appoint a specially trained technician to install the unit.
The assembling operations require the intervention of two persons.

5.1. Unpacking and castors assembling

The unit is delivered on a wooden pallet and protected by a cardboard box.

Pallet and box are held together by two straps.

A copy of the rating plate of the unit is applied also outside the box.

Prepare unpacking as follows:

- Cut the straps with scissors or cutter;
- Lift up the cardboard box;
- Remove any additional packages contained inside and place them on the ground in a stable manner;
- Using scissors or cutter, cut the strap blocking the unit on the pallet;
- Remove any packaging materials such as bubble nylon;
- If castors are already built in the unit, continue with this procedure otherwise go to **note A**;
- Block the front swivel castors by the brake;
- Let the unit slide off the pallet so that the two braked castors can rest on the floor;
- Extract the pallet from beneath the unit and place it carefully on the ground.

Note A:

In case of supply of the unit with castors to build in, it is necessary to proceed as per following instructions:

- Shift the unit about 30cm off the pallet, from the front side;
- Place the castors with brakes under the unit;
- Assemble them in the unit using the screws that are provided in the package;
- Shift the unit about 30 cm off the pallet, from one side;
- Position and assemble one rear castor;
- Extract the pallet from beneath the unit and assemble the second rear castor.



5.2. Assembling the extraction arm

The extraction arm is made up of three main components – rotating part, metal articulating arm assembly and capture hood.

These components are packed in separate boxes and delivered on the same pallet as the unit.

The box containing metal articulating arm assembly contains the Instructions for assembling and adjusting the suction arm. To mount the suction arm on a mobile unit, follow the Instructions provided.

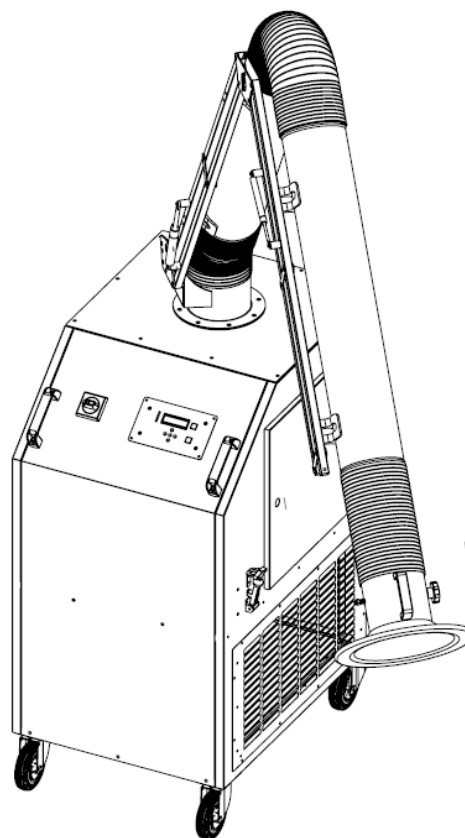

5.3. Active carbons filter (optional)

Whenever required a further filtration stage can be added on some versions of the UNI 2 air cleaner, such as H, E, C, W3.

This is the active carbons filter (used to capture VOC Volatile Organic Compounds).

To insert these filters the air grids need be removed: behind the grid there is a specific slot for the 5kg active carbons filter.

The version UNI 2-K is standard equipped with a.m. active carbons.

The version UNI 2-C-W3 LASER is standard equipped with one active carbons filter against SOV (Volatile Compounds) and another active carbons filter to capture acid and basic gas.



INFO

It is necessary to use protective gloves to avoid possible cuts on hands.
Active carbon is non-toxic and has no effect in case of skin contact.

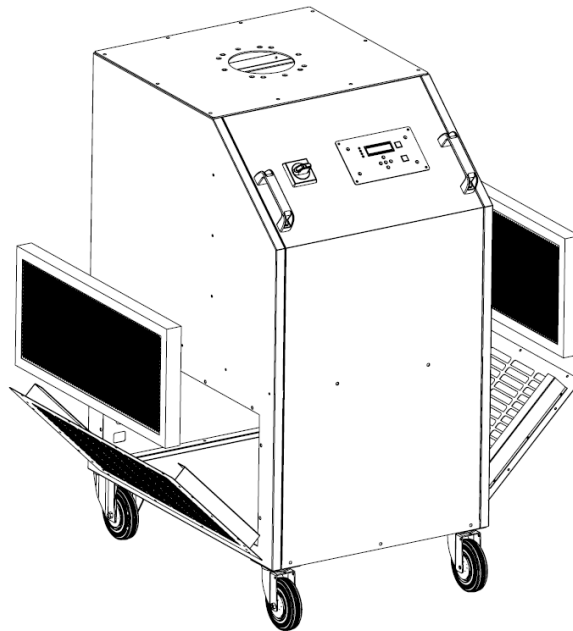

6. USE

Anyone involved in the use, maintenance and repair of the unit must have read and understood this user manual as well as the instructions for accessories and related devices.

6.1. User qualification

The user of the unit can only authorize the use of the unit by personnel with a good knowledge of these operations.

Knowing the unit means that the operators have been trained on the functions, and know the user manual and operating instructions.

The unit shall only be used by qualified or duly trained personnel. Only in this way is it possible to ensure working in a safe manner and in awareness of dangers.

6.2. Control panel

On the front of the unit there is the control panel which is made up of electronic and electromechanical devices.

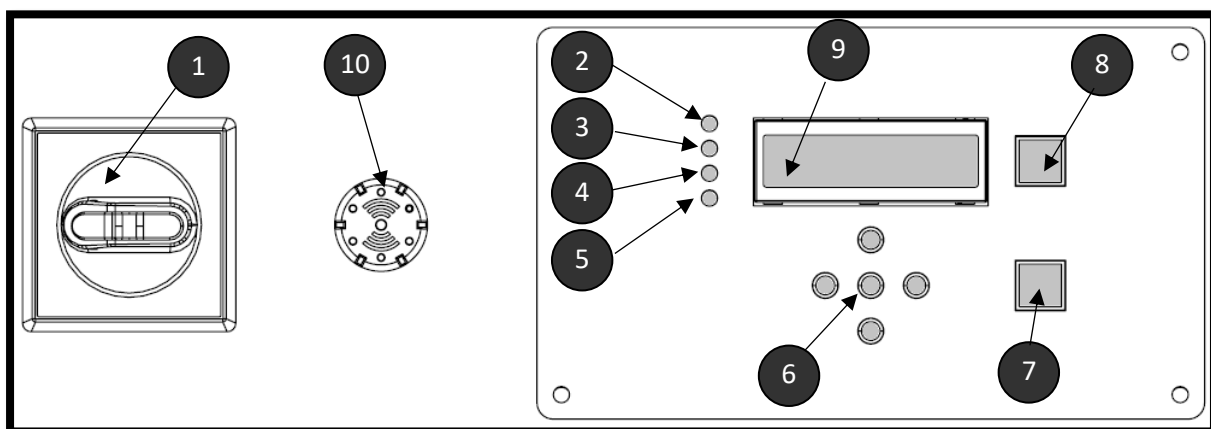

| Pos. | Description | Notes |
|------|--------------------------------------|--|
| 1 | ON-OFF switch | |
| 2 | LED Electric fan is running | |
| 3 | LED Filter-cleaning cycle is running | <i>Active only on units with automatic cleaning</i> |
| 4 | LED Filter clogged | |
| 5 | LED Replace filter | |
| 6 | Control panel keys | |
| 7 | ON to turn on the extraction | |
| 8 | OFF to turn off the extraction | |
| 9 | Pcb data reading display | |
| 10 | Acoustic alarm |  |

Below the detailed description:

- *[Position 1.]*
By turning the switch clockwise, the unit is turned on.
- *[Position 2.]*
After pressing the button ON (pos.7) the signaling LED lights up with a steady green light and indicates that the electric motor has been powered and is running.
- *[Position 3.]*
LED indicator with alternating green light, indicates the start of the cartridge cleaning cycle using compressed air; this signal is active only on versions with self-cleaning.
- *[Position 4.]*
LED indicator with fixed yellow light, turns on after 600 hours of operation to advise to perform a check on the filters (if not replaced yet) and a general check on the unit to verify correct functioning.
- *[Position 5.]*
LED indicator with steady red light, lights up when the filter pressure differential gauge detects a limit pressure difference (data set by the manufacturer) between the dirty air inlet and the clean air outlet in the filtering section.
- *[Position 6.]*
Specific buttons on the control panel to move through the menus and / or modify the parameters.

- [Position 7.]
ON key to start extraction - hold for 3s.
- [Position 8.]
OFF key to switch off extraction - hold for 3s.
- [Position 9.]
Display showing all information about the pcb.
- [Position 10.]
Acoustic alarm, only in version UNI 2 C-W3.



A safe and effective capture of the welding fumes is only possible if there is enough extraction capacity.
The more clogged the filters the narrower the air flow, with a reduction of the extraction capacity!
The acoustic alarm beeps as soon as the extraction capacity falls down below the minimum value.
At that point, the filter needs replacing!
The same happens even if the manual damper in the extraction hood is too closed, significantly reducing the extraction capacity. In this case, open the manual damper.

6.3. Correct positioning of the capture hood

The articulated arm with its capture hood (provided with the unit) has been conceived to make positioning and approaching the source of fumes very easy and dynamic. The capture hood remains in the required position thanks to a multidirectional joint.

In addition, both the hood and the arm can rotate 360°, allowing the suction of fumes in almost any position.

Correct positioning of the capture hood is an essential prerequisite in order to guarantee efficient extraction of welding fumes.

The following figure shows the correct positioning.

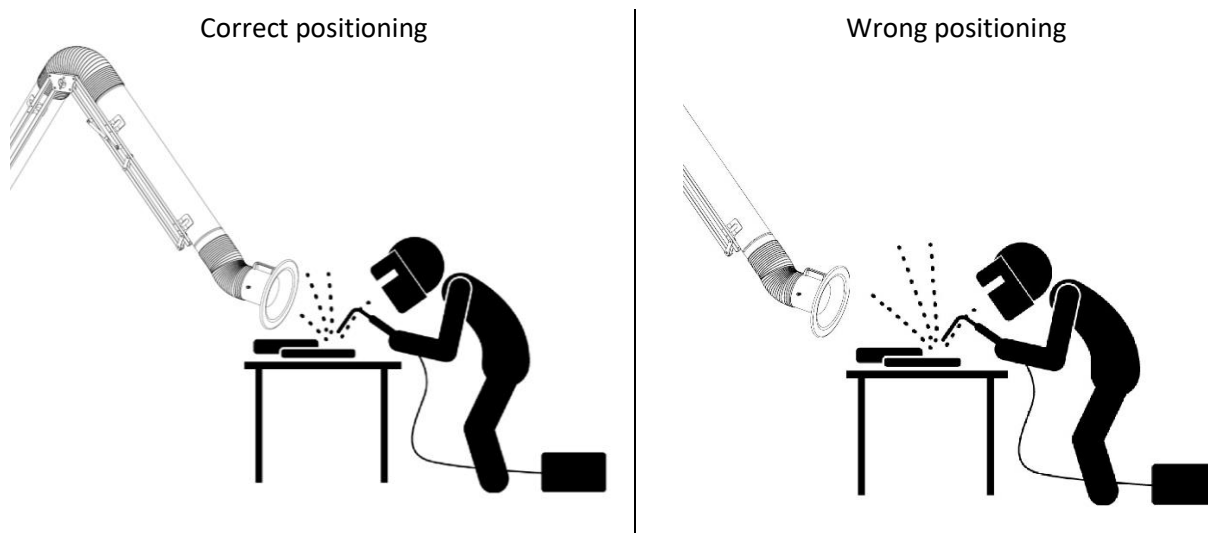

- Position the articulated arm so that the capture hood is positioned transversely to the welding point, at a distance of approximately 25 cm.
- The capture hood must be positioned in such a way as to allow efficient extraction of welding fumes, according to their direction as the temperature and the suction radius vary.
- Always position the capture hood near the relevant welding point.

**WARNING**

In case of incorrect positioning of the capture hood and poor extraction capacity, an efficient extraction of the air containing dangerous substances cannot be guaranteed. In this case, the hazardous substances could penetrate the user's respiratory system, causing damage to health!

6.4. Start of the unit

- Connect the unit to the mains supply; notice the data indicated on the rating plate.
- Switch ON the unit using the yellow-red main switch.
- The control panel is now active, press the ON key on the panel for 3s.
- The fan starts running and the green light indicates that the unit is functioning correctly.
- Finally, always adjust the capture hood in position according to the work process.

6.5. Start of the unit with automatic START-STOP device

The unit can be equipped with an automatic START-STOP electronic device which automatically starts and stops the extraction according to the actual operation of the welding unit.

The device is installed and activated only and exclusively by qualified personnel of Aerservice Equipments, so it is necessary to order from the beginning the unit with this device.

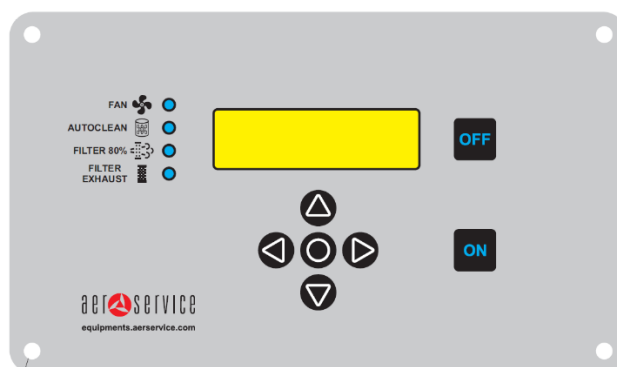

[picture 1: layout of the control panel]

The unit with automatic start and stop function has a special clamp on the side of the unit and also specific indications in the display.

After having turned on the main switch of the unit, the pcb will turn on giving the following information:

- Software version installed
- Name and p/n of the unit
- Then the following information will be shown in the display: START-STOP ACTIVATED.
- The extraction LED  will be flashing.

In this mode the unit is ready to work and it is sufficient to start welding to activate the fume extraction. The unit is already set to stop extracting after 1 minute from the last welding cycle.

MANUAL OPERATION

It is possible to start the unit manually by pressing the ON button for a few seconds.

The message: MANUAL START ACTIVE will appear.

The operation of the filter unit will be active until the OFF button is pressed.

After turning off the extraction, the unit will automatically return to the automatic Start / Stop mode.

When the automatic Start / Stop device is provided on the unit, the clamp for the ground cable of the welding unit is also installed on the side of the filter unit.

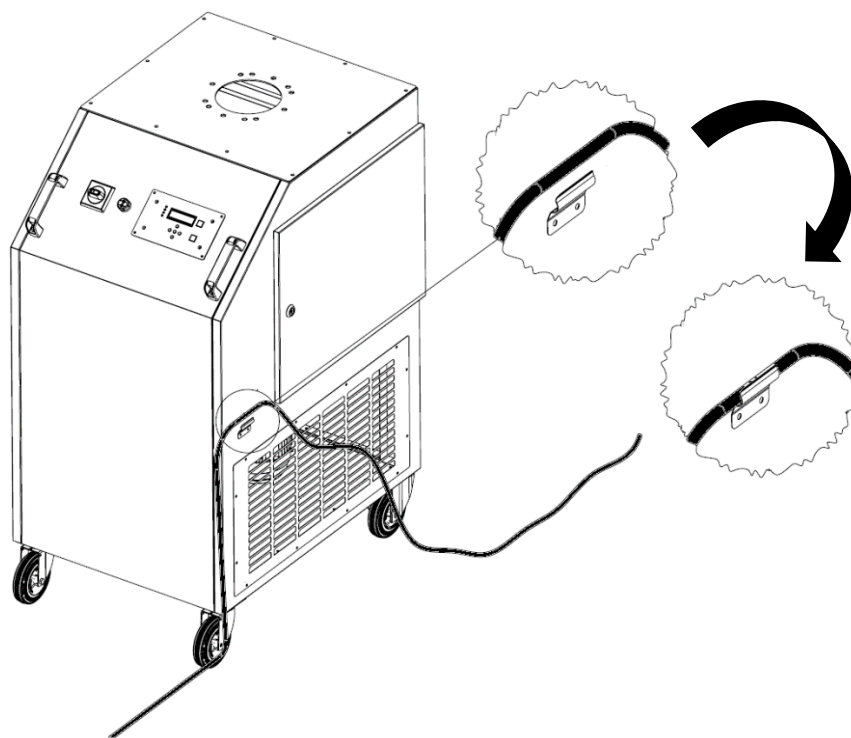

To ensure proper operation of the automatic Start / Stop device, it is essential that the ground cable of the welding unit is placed on the metal cabinet of the filter unit and locked in position by the special clamp. Check that the ground cable is well in contact with the metal cabinet of the unit, as shown in the figure.

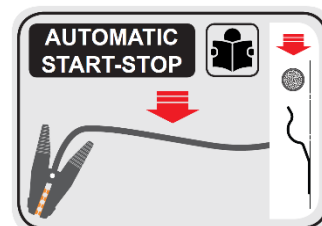

7. REGULAR MAINTENANCE

The instructions in this chapter correspond to the minimum requirements.

Depending on particular operating conditions, other specific instructions may be applicable to keep the unit in a perfect conditions.

The maintenance and repairs described in this chapter may only be performed by qualified personnel.

The spare parts used must correspond to the technical requirements established by Aerservice Equipments.

This is always guaranteed if original spare parts are used.

Dispose in a safe and environmentally friendly way of the materials used and the components replaced.

Respect the following instructions during maintenance:

- Chapter 2.4 Safety warnings for the operator;
- Chapter 2.5 Safety warnings for maintenance and troubleshooting;
- Specific safety warnings, reported in this chapter in correspondence with each intervention.

7.1. CARE

Taking care of the unit essentially means cleaning the surfaces, removing dust and deposits, and checking the condition of the filters.

Follow the warnings indicated in the "Safety instructions for repairing and troubleshooting" chapter.



WARNING

Skin contact with dust and other substances deposited on the unit can cause irritation to sensitive persons!
 Danger of serious damage to the respiratory system!
 To avoid contact and inhalation of dust, it is recommended to use protective clothing, gloves and a mask with a FFP2 class filter according to EN 149 standard.
 During cleaning, prevent dangerous dust from being diffused in order to avoid damage to the health of persons nearby.



INFO

The unit must not be cleaned with compressed air!
 Particles of dust and / or dirt could be diffused in the surrounding environment.

Adequate consideration helps to keep the unit in perfect order for a long time.

- The unit shall be cleaned thoroughly every month.
- The external surfaces of the unit shall be cleaned with a "H" class industrial vacuum cleaner suitable for dust, or with a damp cloth.
- Check that the suction arm is not damaged, and that there are no breaks / cracks in the flexible hose.

7.2. Ordinary maintenance

To ensure a safe operation of the unit, it is advisable to carry out a maintenance activity and overall check at least once every 3 months.

The unit does not require any specific maintenance, except for the replacement of the filters if necessary and the inspection of the articulated arm.

Follow the warnings given in paragraph 2.5 "Safety warnings for maintenance and troubleshooting".

7.3. Replacement of filters

The lifetime of the filters depends on the kind and quantity of particles extracted.

To optimize the life of the main filter and to protect it from coarser particles, all units are provided with a pre-filtration stage.

It is advisable to periodically replace prefilters (consisting of 1 or 2 filters depending on the version), depending on the use, for example every day, week or month, and not to wait for complete clogging. The more are clogged the filters the narrower is the air flow, with a reduction of the extraction capacity. In most cases it is sufficient to replace the prefilters. Only after several replacements of prefilters will the main filter also need to replacing.

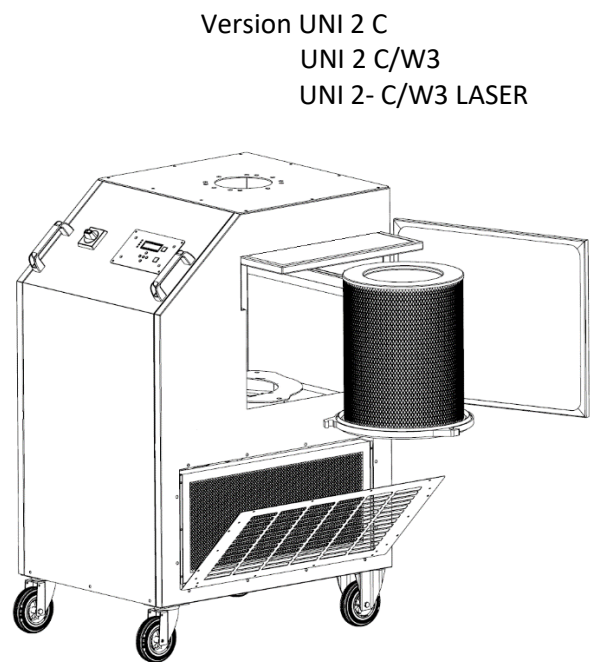
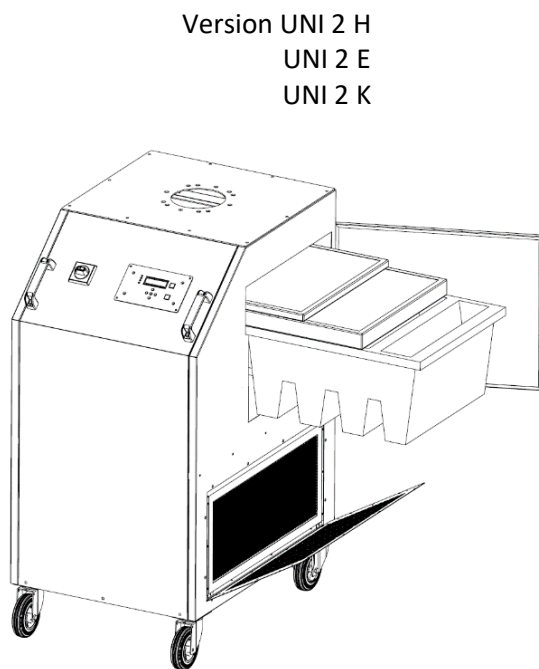

**INFO**

The acoustic alarm beeps as soon as the extraction capacity falls down below the minimum value.

**WARNING**

It is forbidden to clean fabric filters (all kinds): corrugated, pocket and cartridge filters. Cleaning would cause damage to the filter stuff, compromising the function of the filter and leading to escape of hazardous substances into the ambient air. In case of a cartridge filter, pay particular attention to the filter seal; only if the seal is free from damages or imperfections it is possible to guarantee a high level of filtration. Filters with damaged seals shall always be replaced.

**WARNING**

Skin contact with dust and other substances lying on the unit can cause irritation to sensitive persons!
Danger of serious damage to the respiratory system!
To avoid contact and inhalation of dust, it is recommended to use protective clothing, gloves and a mask with a FFP2 class filter according to EN 149 standard.
During cleaning, prevent dangerous dust from being diffused in order to avoid damage to the health of other persons.
To this purpose, carefully insert the dirty filters inside bags with sealing and use an industrial vacuum cleaner for dust with efficiency class "H" to suck up any dust dropped during the filter extraction phase.

Depending on the version of the unit, proceed with the following instructions:

1. Instructions for UNI 2 H and UNI 2 K version

- Use only original replacement filters, as only these filters can guarantee the required filtration level and are suitable for the unit and its performance.
- Turn off the unit by the yellow-red main switch.
- Secure the unit by pulling out the plug from the mains, so that it cannot be accidentally restarted.
- Open the inspection door on the side of the unit.

a) Replacing the prefilter

- Carefully remove the metal prefilter and the intermediate filter, in order to avoid any lifting up of dust.
- Carefully place the filters in a plastic bag, while avoiding any dust diffusion, and close it, for example with cable ties.
- Suitable plastic bags can be supplied by Aerservice Equipments.
- Insert the new filters in the guides making sure to respect the original order.

b) Replacing the main filter

- Carefully take out the pocket filter, taking care to avoid any dust diffusion.
- Put the filter in a plastic bag and close it, for example with cable ties.
- Suitable plastic bags can be supplied by Aerservice Equipments.
- Insert the new filter in the guides.

c) If active carbons filters are provided, proceed as follows:

- Open the air grids on both sides of the cabinet.
- Carefully take out each filter avoiding any dust diffusion and place it in a sealed plastic bag.
- Insert the new filters in the guides behind each grid and fasten again with the screws.

d) Once the filters have been replaced, proceed as per the following steps:

- Close the inspection door and, depending on the model, check that it is completely closed and that the sealing gasket is positioned correctly.
- Reinsert the plug into the mains socket and turn on the yellow-red main switch.
- Reset alarms as indicated under point 7.4.
- Dispose of the dirty filters according to the regulations in force locally. Ask the local waste disposal company for the relevant waste disposal codes.
- Finally clean the surrounding area, e.g. with an "H" class industrial vacuum cleaner for dust.

2. Instructions for UNI 2 C version and UNI 2 C-W3 / UNI 2 C-W3 Laser

- Use only original replacement filters, as only these filters can guarantee the required filtration level and are suitable for the unit and its performance.
- Turn off the unit by the yellow-red main switch.
- Secure the unit by pulling out the plug from the mains, so that it cannot be accidentally restarted.
- Open the inspection door on the side of the unit.

a) Replacing the prefilter

- Carefully remove the metal prefilter, in order to avoid any lifting up of dust.
- Carefully place the filter in a plastic bag, while avoiding raising any dust, and close it, for example with cable ties.
- Suitable plastic bags can be supplied by Aerservice Equipments.
- Insert the new filter in the guides.

b) Replacing the main filter

- Carefully take out the cartridge filter, taking care to avoid any lifting up of dust.
- To extract it, it is necessary to loosen the 3 screws on the flange and then rotate the cartridge in order to release it from the hooks.
- Carefully place the filter in a plastic bag and close it, for example with cable ties.
- Suitable plastic bags can be supplied by Aerservice Equipments.
- Insert the new cartridge filter in the special support inside the unit and by rotating the cartridge fasten with the screws.
- Tighten the screws again so as to put the sealing gasket under pressure.

c) If active carbons filters are provided, proceed as follows:

- Open the air grids on both sides of the cabinet (one unique air grid on UNI 2 C-W3 Laser).
- Carefully take out each filter avoiding any dust diffusion and place it in a sealed plastic bag.
- Insert the new filters in the guides behind each grid and fasten again with the screws.

d) Once the filters have been replaced, proceed as per the following steps:

- Close the inspection door and, depending on the model, check that it is completely closed and that the sealing gasket is positioned correctly.
- Reinsert the plug into the mains socket and turn on the yellow-red main switch.
- Reset alarms as indicated under point 7.4.
- Dispose of the dirty filters according to the regulations in force locally. Ask the local waste disposal company for the relevant waste disposal codes.
- Finally clean the surrounding area, e.g. with an "H" class industrial vacuum cleaner for dust.

3. Instructions for UNI 2 E version

- Use only original replacement filters, as only these filters can guarantee the required filtration level and are suitable for the unit and its performance.
- Turn off the unit by the yellow-red main switch.
- Secure the unit by pulling out the plug from the mains, so that it cannot be accidentally restarted.
- Open the inspection door on the side of the unit.

a) Replacing the prefilter

- Carefully remove the metal prefilter and the intermediate filter, in order to avoid any lifting up of dust.
- Carefully place the filters in a plastic bag, while avoiding any dust diffusion, and close it, for example with cable ties.
- Suitable plastic bags can be supplied by Aerservice Equipments.
- Insert the new filters in the guides making sure to respect the original order.

b) Regeneration of the electrostatic filter



INFO

The electrostatic filter of the unit UNI 2 E does not need replacing and can be regenerated. A specific washing procedure allows the filter to be cleaned and re-used.



WARNING

Skin contact with dust and other substances lying on the filter may cause irritation to sensitive people!
 Danger of serious damages to the respiratory system!
 Danger of serious eye damages during washing!
 To avoid contact and inhalation of dust or splashes of rinsing liquid, it is recommended to use protective clothing, gloves, a mask with a class FFP2 filter according to EN 149 and protective goggles for the eyes.

- Disconnect the electric power connector from the filter.
- Carefully remove the electrostatic filter, avoiding any lifting up of dust.
- Extract the pre-filter incorporated in the electrostatic filter by lifting it for about one centimeter and extract it as shown in the figure.
- Provide:
 - A plastic or stainless-steel tank with decanting bottom;
 - Rinsing liquid, available from Aerservice Equipments:
p/n ACC00MFE000080;
 - Running water.

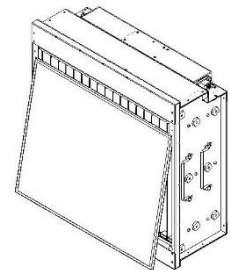

- Use a stainless-steel frame to keep the filters off the bottom of the tank and allow decanting of sludge.
- Pour lukewarm (maximum 45 ° C) or cold water. Add the diluted rinsing liquid according to the proportions shown on the label.
- Dip the electrostatic filter in the tank, let it soaking for the time indicated in the instructions or until the dirt has completely dissolved from the cell.
- Take up the filter, let it drip over the tank, rinse thoroughly under running water, taking care not to break the ionization wires.
- Let the filter dry by keeping it raised from the floor with wooden strips or in a dryer with a maximum temperature 60° C.
- Make sure that the electrostatic filter is clean and dry, then insert it in the guides inside the unit.

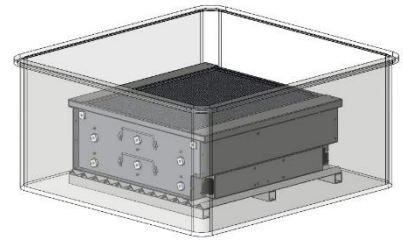

INFO

Some alkaline-based rinsing liquids can leave residues on the surface of the blades and isolators, which cannot be removed by simple rinsing and which result in voltage losses and therefore in less efficiency (up to 50%) of the electrostatic cell in case of ambient humidity. To remedy this effect, dip the cell in an acidulated bath for a few minutes and then rinse it again.

Wash the pre-filter in the same way, taking care not to damage it by bending it or by weakening the filter mesh. The Manufacturer cannot be held liable for any breakdowns, malfunctions or shorter lifetime if maintenance is not carried out according to the present provisions.

c) If active carbons filters are provided, proceed as follows:

- Open the air grids on both sides of the cabinet.
- Carefully take out each filter avoiding any dust diffusion and place it in a sealed plastic bag.
- Insert the new filters in the guides behind each grid and fasten again with the screws.

d) Once the filters have been replaced, proceed as per the following steps:

- Close the inspection door and, depending on the model, check that it is completely closed and that the sealing gasket is positioned correctly.
- Reinsert the plug into the mains socket and turn on the yellow-red main switch.
- Reset alarms as indicated under point 7.4.
- Dispose of the dirty filters according to the regulations in force locally. Ask the local waste disposal company for the relevant waste disposal codes.
- Finally clean the surrounding area, e.g. with an "H" class industrial vacuum cleaner for dust.

7.4. Digital control panel: alarms and alarm reset

The mobile air cleaner is equipped with a pc board for the control and setting of all functions.

Picture no. 1 shows the front panel where the user can set and read data.

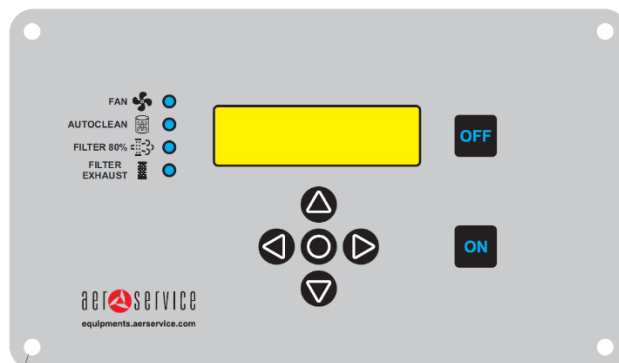

[picture 1: pc board layout]

Alarms are managed by the software in the following way:

- **FILTER 80%:** it turns on after 600 hours of operation to indicate that an overall check of filters is necessary (if not cleaned or replaced before) and of the unit as well, to verify if it operates correctly.
- **FILTER EXHAUST:** it turns on when the filter pressure differential gauge detects a specific difference value (set by the Manufacturer) between the inlet of dirty air and the outlet of clean air on the filter.

In addition to the visual alarm on the control panel, the unit is also equipped with an acoustic signal generated by a buzzer.

From version 00.08 it is possible to deactivate the acoustic signal and keep only the lighting alarm.

On the pc board there are the following menus:

- TEST MENU
- USER MENU
- ASSISTANCE MENU
- FACTORY MENU

When the Filter Exhaust alarm turns on, it is necessary to replace the filters as indicated under point 7.3 and to reset alarms in order to restore normal operation.

To carry out the reset it is necessary to enter the **USER** menu.

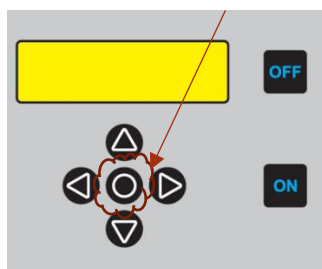

To enter the User menu just press once the button: central circle (O).

Then the unit will request a password, which is the following key sequence: central circle (O) + central circle (O) + central circle (O) + central circle (O) + central circle (O) + central circle (O).

Once you have entered the menu, scroll down (↓) to the third position **ALARMS RESET**.

Press the central button (O) to go in and then type the following key sequence: arrow down (↓), arrow down (↓), arrow up (↑), arrow up (↑), circle (O), circle (O).

At this point the alarms are reset and all settings return to zero.

Remember that alarm reset is linked with the maintenance, cleaning or replacement of the filters.

The Manufacturer cannot be held liable for any breakdowns, malfunctions or shorter lifetime if alarms reset and maintenance are not carried out according to the present provisions.

Aerservice Equipments provides the unit with all alarm functions activated. Any deactivation of alarm is not attributable to the Manufacturer but to interventions carried out by the user or, eventually, by the dealer.

Aerservice Equipments recommends not to turn off any alarm, in order to maintain a high level of control over the unit and the maintenance of filters and to safeguard the performance of the unit and the health of the user.

Inside the USER MENU there is also the FIL.BUZ.ALERT. function, about the alarms with buzzer.

It is possible to set three levels of this functions, as follows:

- NO: the buzzer acoustic signal is not active.
- EXHAUST: the buzzer acoustic signal is activated by the filter pressure differential gauge.
- DIRTY/EXHAUST: the buzzer acoustic signal is activated both by the filter pressure differential gauge and by the internal hour meter set by the factory.

**WARNING**

It is strictly forbidden to reset the alarms without having performed the necessary maintenance!

Aerservice Equipments is exonerated from any responsibility if these instructions are not respected.

7.5. Troubleshooting

| FAILURE | POSSIBLE CAUSE | ACTION REQUIRED |
|---|---|---|
| The unit does not turn on | No power supply | Contact an electrician |
| | Pc board protection fuse is blown | Replace the 5x20 3.15A fuse |
| | The Start / Stop sensor (optional) is connected but does not detect any current | Ensure that the ground cable of the welding unit is correctly clamped on the filter units Start welding, if you have not yet |
| The extraction capacity is poor | Filters are dirty | Replace filters |
| | Wrong rotating direction of the motor (three-phase 400V version) | Consult an electrician to reverse two phases in the CEE plug |
| Presence of dust in the air expulsion grid | Damaged filters | Replace filters |
| Not all fumes are captured | Excessive distance between the capture hood and the welding point | Bring the hood closer |
| | Manual damper is rather closed | Fully open the damper |
| The acoustic alarm is ON as well as the red light FILTER EXHAUST  | The extraction capacity is not enough | Replace filters |

| SPECIFIC FAULTS FOR THE AIR CLEANER UNI 2 E | | |
|---|--|---|
| Malfunction of the electrostatic filter | Ionization wires are broken | Replace ionization wires |
| | Ionization wires are oxidized or dirty | Clean the wire with a cloth soaked in alcohol or with synthetic abrasive wool |
| | Dirty ceramic isolator | Wash again the electrostatic filter |
| | The ceramic isolator is broken | Contact Aerservice Equipments |
| | High voltage contacts are burnt out | |

7.6. Emergency measures

In the event of a fire in the unit or in its suction device, proceed as follows:

- Disconnect the unit from the mains supply, removing the plug from the socket, if possible.
- Try to extinguish the outbreak of fire with a standard powder extinguisher.
- If necessary, contact the fire brigade.



WARNING

Do not open the inspection doors of the unit.
Possibility of flare-ups!
In case of fire, do not touch the unit for any reason without suitable protective gloves.
Danger of burns!

8. DISPOSAL



WARNING

Skin contact with dangerous fumes etc. can cause skin irritation in sensitive individuals.
The disassembly of the unit shall be carried out exclusively by specialized personnel, trained and authorized, in compliance with the safety instructions and the regulations for accident prevention.
Possibility of serious damage to health, affecting the respiratory system.
To avoid contact and inhalation of dust, wear protective clothing, gloves and a respirator!
Avoid any diffusion of dangerous dust during disassembly, in order not to jeopardize the health of people nearby.
Use a class "H" industrial vacuum cleaner to clean up the area.



WARNING

For all activities performed on and with the unit, comply with the legal obligations for the prevention of accidents and for correct recycling / disposal of waste.

8.1. Plastics

Any plastic materials shall be picked out as much as possible and disposed in compliance with legal obligations.

8.2. Metals

Metals, such as the cabinet of the unit, shall be separated and disposed in accordance with the local regulations. Disposal shall be carried out by an authorized company.

8.3. Filter media

Any filtering media used shall be disposed of in compliance with local obligations.

8.4. Waste liquids

The waste liquids created during washing and regeneration of the electrostatic filter shall not be dispersed in the environment.

Disposal shall be carried out by an authorized company.

9. ATTACHMENTS

9.1.1. UNI 2 H Technical data

FILTRATION DATA

| DESCRIPTION | UM | VALUE | NOTES |
|----------------------|----------------|------------------|--|
| FILTER STAGES | No | 3 | Spark arrestor - prefilter Intermediate filter EPA pocket filter |
| FILTERING SURFACE | m ² | 14,5 | EPA pocket filter |
| FILTER | Material | Glass microfibre | EPA pocket filter |
| EFFICIENCY | | ≥99,5% | EPA pocket filter |
| FUMES CLASSIFICATION | EN 1822:2009 | E12 | EPA pocket filter |
| ACTIVE CARBONS | Kg | 10 (5+5) | Optional |

EXTRACTION DATA

| DESCRIPTION | UM | VALUE | NOTES |
|-----------------------------|-------------------|-------------|-----------------------------|
| EXTRACTION CAPACITY | m ³ /h | 1.100 | Measured with clean filters |
| MAX FAN CAPACITY | m ³ /h | 2.500 | |
| NOISE LEVEL | dB(A) | 70 | |
| <i>Single-phase version</i> | | | |
| MOTOR POWER | kW | 1,1 | |
| MAINS SUPPLY | V/ph/Hz | 230/1/50 | |
| ABSORBED CURRENT | A | 7,67 | |
| <i>Three-phase version</i> | | | |
| MOTOR POWER | kW | 1,1 | |
| MAINS SUPPLY | V/ph/Hz | 400/3/50-60 | |
| ABSORBED CURRENT | A | 2,55 | |

ADDITIONAL INFORMATION

| DESCRIPTION | UM | VALUE | NOTES |
|----------------------|------|-----------------|------------------------------------|
| EXTRACTOR | Type | Centrifugal fan | |
| CLOGGED FILTER ALARM | Pa | 650 | Filter pressure differential gauge |
| START&STOP | Type | automatic | Optional |
| DIMENSION | mm | 600x1200x800 | |
| WEIGHT | Kg | 105 | |

9.1.2. UNI 2 E Technical data

FILTRATION DATA

| DESCRIPTION | UM | VALUE | NOTES |
|----------------------|-------------------|----------------------|---|
| FILTER STAGES | No | 3 | Spark arrestor - prefilter Intermediate filter Electrostatic filter |
| STORAGE CAPACITY | g | 460 | Electrostatic filter |
| MAX. CONCENTRATION | mg/m ³ | 20 | Electrostatic filter |
| EFFICIENCY | | ≥95% | Electrostatic filter |
| FUMES CLASSIFICATION | UNI 11254 | A | Electrostatic filter |
| | EN 1822:2009 | E11 | Electrostatic filter |
| | ISO 16890-2:2016 | Epm ₁ 95% | Electrostatic filter |
| ACTIVE CARBONS | Kg | 10 (5+5) | Optional |

EXTRACTION DATA

| DESCRIPTION | UM | VALUE | NOTES |
|-----------------------------|-------------------|-------------|-----------------------------|
| EXTRACTION CAPACITY | m ³ /h | 1.480 | Measured with clean filters |
| MAX FAN CAPACITY | m ³ /h | 2.500 | |
| NOISE LEVEL | dB(A) | 70 | |
| <i>Single-phase version</i> | | | |
| MOTOR POWER | kW | 1,1 | |
| MAINS SUPPLY | V/ph/Hz | 230/1/50 | |
| ABSORBED CURRENT | A | 7,67 | |
| <i>Three-phase version</i> | | | |
| MOTOR POWER | kW | 1,1 | |
| MAINS SUPPLY | V/ph/Hz | 400/3/50-60 | |
| ABSORBED CURRENT | A | 2,55 | |

ADDITIONAL INFORMATION

| DESCRIPTION | UM | VALUE | NOTES |
|----------------------|------|-----------------|--------------------|
| EXTRACTOR | Type | Centrifugal fan | |
| CLOGGED FILTER ALARM | - | - | Electronic control |
| START&STOP | Type | automatic | Optional |
| DIMENSION | mm | 600x1200x800 | |
| WEIGHT | Kg | 105 | |

9.1.3. UNI 2 C Technical data

FILTRATION DATA

| DESCRIPTION | UM | VALUE | NOTES |
|---------------------------|------------------------|-----------|---|
| FILTERING STAGES | No | 2 | Spark arrester - prefilter Cartridge filter |
| FILTERING SURFACE | m ² | 12,55 | Cartridge filter |
| FILTER | Material | Ultra-web | Cartridge filter |
| EFFICIENCY | > | 99% | Cartridge filter |
| DUST CLASSIFICATION | DIN EN 60335-2-69:2010 | M | Test report num.: 201720665/6210 Cartridge filter |
| FILTERING MEDIA WEIGHT | g/m ² | 114 | Cartridge filter |
| FILTERING MEDIA THICKNESS | mm | 0,28 | Cartridge filter |
| ACTIVE CARBONS | Kg | 10 (5+5) | Optional |

EXTRACTION DATA

| DESCRIPTION | UM | VALUE | NOTES |
|-----------------------------|-------------------|-------------|-----------------------------|
| EXTRACTION CAPACITY | m ³ /h | 1.100 | Measured with clean filters |
| MAX FAN CAPACITY | m ³ /h | 2.500 | |
| NOISE LEVEL | dB(A) | 70 | |
| <i>Single-phase version</i> | | | |
| MOTOR POWER | kW | 1,1 | |
| MAINS SUPPLY | V/ph/Hz | 230/1/50 | |
| ABSORBED CURRENT | A | 7,67 | |
| <i>Three-phase version</i> | | | |
| MOTOR POWER | kW | 1,1 | |
| MAINS SUPPLY | V/ph/Hz | 400/3/50-60 | |
| ABSORBED CURRENT | A | 2,55 | |

ADDITIONAL INFORMATION

| DESCRIPTION | UM | VALUE | NOTES |
|----------------------|------|-----------------|------------------------------------|
| EXTRACTOR | Type | Centrifugal fan | |
| CLOGGED FILTER ALARM | Pa | 1000 | Filter pressure differential gauge |
| START&STOP | Type | automatic | Optional |
| DIMENSION | mm | 600x1200x800 | |
| WEIGHT | Kg | 105 | |

9.1.4. UNI 2 C – W3 / UNI 2 C – W3 Laser Technical data

FILTRATION DATA

| DESCRIPTION | UM | VALUE | NOTES |
|---|--|-----------|---|
| FILTRATION EFFICIENCY CLASS – WELDING FUMES | UNI EN ISO 21904-1:2020 UNI EN ISO 21904-2:2020 | W3 ≥99% |  DGUV Certificate No. IFA 2005015 |
| FILTERING STAGES | No | 2 | Spark arrestor - prefilter Cartridge filter |
| FILTERING SURFACE | m ² | 12,55 | Cartridge filter |
| FILTER | Material | Ultra-web | Cartridge filter |
| EFFICIENCY | > | 99% | Cartridge filter |
| DUST CLASSIFICATION | DIN EN 60335-2-69:2010 | M | Test report num.: 201720665/6210 Cartridge filter |
| FILTERING MEDIA WEIGHT | g/m ² | 114 | Cartridge filter |
| FILTERING MEDIA THICKNESS | mm | 0,28 | Cartridge filter |
| ACTIVE CARBONS | Kg | 10 (5+5) | Optional – for SOV on UNI 2 C W3 |
| ACTIVE CARBONS | Kg | 10 (5+5) | Standard – for SOV and acid/basic fumes on UNI 2 C W3 Laser |

EXTRACTION DATA

| DESCRIPTION | UM | VALUE | NOTES |
|-----------------------------|-------------------|-------------|--|
| EXTRACTION CAPACITY | m ³ /h | 1.100 | Measured with clean filters |
| MINIMUM EXTRACTION CAPACITY | m ³ /h | 700 |  Triggering level for air flow control |
| MAX FAN CAPACITY | m ³ /h | 2.500 | |
| NOISE LEVEL | dB(A) | 70 | |
| <i>Single-phase version</i> | | | |
| MOTOR POWER | kW | 1,1 | |
| MAINS SUPPLY | V/ph/Hz | 230/1/50 | |
| ABSORBED CURRENT | A | 7,67 | |
| <i>Three-phase version</i> | | | |
| MOTOR POWER | kW | 1,1 | |
| MAINS SUPPLY | V/ph/Hz | 400/3/50-60 | |
| ABSORBED CURRENT | A | 2,55 | |

ADDITIONAL INFORMATION

| DESCRIPTION | UM | VALUE | NOTES |
|----------------------|------|-----------------|------------------------------------|
| EXTRACTOR | Type | Centrifugal fan | |
| CLOGGED FILTER ALARM | Pa | 1000 | Filter pressure differential gauge |
| START&STOP | Type | automatic | Optional |
| DIMENSION | mm | 600x1200x800 | |
| WEIGHT | Kg | 105 | |

9.1.5. UNI 2 K Technical data

FILTRATION DATA

| DESCRIPTION | UM | VALUE | NOTES |
|----------------------|----------------|------------------|---|
| FILTERING STAGES | No | 4 | Spark arrestor - prefilter Intermediate filter EPA pocket filter with active carbons Active carbon post filter |
| FILTERING SURFACE | m ² | 6 | EPA pocket filter with active carbons |
| FILTER | Material | Non-woven fabric | EPA pocket filter with active carbons |
| EFFICIENCY | | ≥80% | EPA pocket filter with active carbons |
| FUMES CLASSIFICATION | EN 779:2012 | M6 | EPA pocket filter with active carbons |
| ACTIVE CARBONS | Kg | 12,1 | Total of carbon filters |
| STORAGE CAPACITY | Kg | 1,8 | Total of carbon filters |

EXTRACTION DATA



| DESCRIPTION | UM | VALUE | NOTES |
|-----------------------------|-------------------|-------------|-----------------------------|
| EXTRACTION CAPACITY | m ³ /h | 1.100 | Measured with clean filters |
| MAX FAN CAPACITY | m ³ /h | 2.500 | |
| NOISE LEVEL | dB(A) | 70 | |
| <i>Single-phase version</i> | | | |
| MOTOR POWER | kW | 1,1 | |
| MAINS SUPPLY | V/ph/Hz | 230/1/50 | |
| ABSORBED CURRENT | A | 7,67 | |
| <i>Three-phase version</i> | | | |
| MOTOR POWER | kW | 1,1 | |
| MAINS SUPPLY | V/ph/Hz | 400/3/50-60 | |
| ABSORBED CURRENT | A | 2,55 | |

ADDITIONAL INFORMATION

| DESCRIPTION | UM | VALUE | NOTES |
|----------------------|------|-----------------|------------------------------------|
| EXTRACTOR | Type | Centrifugal fan | |
| CLOGGED FILTER ALARM | Pa | 650 | Filter pressure differential gauge |
| START&STOP | Type | automatic | Optional |
| DIMENSION | mm | 600x1200x800 | |
| WEIGHT | Kg | 117 | |

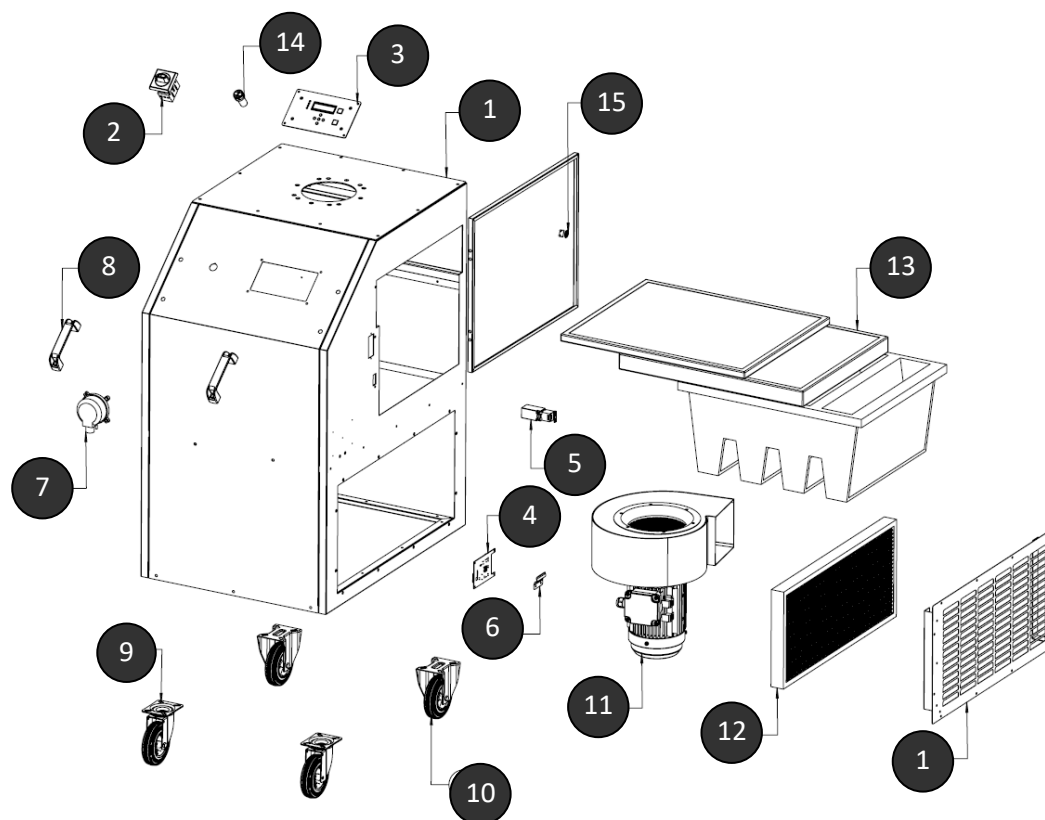
9.2. Spare parts and accessories



| N° | P/N | UM | Q.ty | Description |
|----|----------------|----|------|--|
| 1 | 50FILU02200 | No | 1 | Unit black cabinet |
| 2 | 2050060 | No | 1 | 16A main switch |
| 3 | DBCENT0M230000 | No | 1 | Control pc board |
| 4 | DBCENT0M2300SS | No | 1 | Start/stop pc board |
| 5 | ACCOMFE0000070 | No | 1 | Safety micro for filter inspection door |
| 6 | COM00173 | No | 1 | Rubber clamp for ground cable of the welding unit |
| 7 | 3240005 | No | 1 | Filter pressure differential gauge |
| 8 | DBMANUNI20 | No | 2 | Handle |
| 9 | DBRUOTAFRENO | No | 2 | Swivel castor with brake |
| 10 | DBRUOTAFISSA | No | 2 | Rear castor |
| 11 | SELFUNI022020 | No | 1 | Extractor fan 1phase 230V 1.1kW |
| | SELFUNI022040 | No | 1 | Extractor fan 3phase F 400V 1.1kW |
| 12 | RFOUNI2200003 | No | 1 | Set of 2pcs active carbon filter [5+5Kg] |
| 13 | RFOUNI2200000 | No | 1 | Set of replacement filters for UNI 2 H |
| | RFOUNI2200024 | No | 1 | Set of replacement filters for UNI 2 C |
| | RFOUNI2200021 | No | 1 | Set of replacement filters for UNI 2 C W3 |
| | RFOUNI2200012 | No | 1 | Set of replacement filters for UNI 2 K |
| | RFOUNI2200026 | No | 1 | Set of replacement filters for UNI 2 C W3 Laser |
| | RFOUNI2200001 | No | 1 | Set of prefilters for UNI 2 E |
| | RFOUNI2200015 | No | 1 | Electrostatic filter for UNI 2 E |
| 14 | 2300054 | No | 1 | Acoustic alarm  |
| 15 | COM00085 | No | 1 | 1/4 turn lock |
| | COM00143 | No | 1 | Handle  |

9.3.1. EC declaration of conformity

THE MANUFACTURER

Aerservice Equipments Srl

Company

Viale dell'Industria, 24

Address

35020

Postal code

Legnaro

City

Padova

Province

Italy

Country

DECLARES THAT THE PRODUCT

Mobile filter unit for the extraction of welding fumes

Description

Serial number

Year of manufacture

UNI 2

Commercial name

Extraction and filtration of welding fumes in non-heavy processes in absence of oil and grease

Intended use

IS IN COMPLIANCE WITH THE FOLLOWING DIRECTIVES

Directive 2006/42/EC of the European Parliament and Council, May 17th 2016, on machinery amending directive 95/16/EC.

Directive 2014/30/EU of the European Parliament and Council, February 26th 2014, on the approximation of the laws of the member States relating to electromagnetic compatibility.

Directive 2014/35/EU of the European Parliament and Council, February 26th 2014, on the approximation of the laws of the member States relating to electrical equipment destined to be used within certain voltage limits.

Directive 2011/65/EU of the European Parliament and Council, June 8th 2011, on the restriction of the utilization of certain substances in the electric and electronic devices.

The following harmonized standards have been applied

UNI EN ISO 12100:2010: Safety of machinery - General principles for design - Risk assessment and risk reduction.

UNI EN ISO 13849-1:2016: Safety of machinery - Safety-related parts of control units - Part 1: General principles for design.

UNI EN ISO 13849-2:2013: Safety of machinery - Safety-related parts of control units - Part 2: Validation.

UNI EN ISO 13857:2020: Safety of machinery - Safety distances to prevent hazard zones being reached by upper and lower limbs.

CEI EN 60204-1:2018: Safety of machinery - Electrical equipment of units - Part 1: General requirements.

And exclusively for the model UNI 2 C-W3

UNI EN 21904-1:2020: Safety in Welding - Devices for the capture and separation of welding fumes - Part 1: General requirements

UNI EN 21904-2:2020: Safety in Welding - Devices for the capture and separation of welding fumes - Part 2: Test requirements

The complete list of applied standards, guidelines and specifications are available at the Manufacturer.

Additional information: The declaration of conformity decays in case of non-compliant use and in the event of configuration changes that have not been previously approved by the Manufacturer in writing.

DECLARES THAT THE TECHNICAL FILE

Has been compiled, and is kept and available at the registered office of the Company.

Place and date of the document

Legnaro,

The Manufacturer

Marco Gallerino



9.3.2. UK Declaration of Conformity (UKCA)

THE MANUFACTURER

Aerservice Equipments S.r.l.

Company

Viale dell'Industria, 24

Address

35020

Postal code

Legnaro

City

Padova

Province

Italy

Country

DECLARES THAT THE UNIT

Mobile filter unit for the extraction of welding fumes

Description

Serial number

Year of manufacture

UNI 2

Commercial name

Extraction and filtration of welding fumes in non-heavy processes in absence of oil and grease

Intended use

IS IN COMPLIANCE WITH THE FOLLOWING DIRECTIVES

Machinery: The Supply of Machinery (Safety) Regulations 2008.

EMC: Electromagnetic Compatibility Regulations 2016.

LVD: The Electrical Equipment (Safety) Regulations 2016.

RoHS: Restriction of the Use of Certain Hazardous Substances in Electrical and Electronic Equipment Regulations 2012.

The following harmonized standards have been applied

- S.I. 2008 No. 1597: Safety of machinery - General principles for design - Risk assessment and risk reduction (ISO 12100:2010)
- S.I. 2008 No. 1597: Safety of machinery - Safety-related parts of control units - Part 1: General principles for design (ISO 13849-1:2015)
- S.I. 2008 No. 1597: Safety of machinery - Safety-related parts of control units - Part 2: Validation (ISO 13849-2:2012)
- S.I. 2008 No. 1597: Safety of machinery - Safety distances to prevent hazard zones being reached by upper and lower limbs (ISO 13857:2008)
- S.I. 2008 No. 1597: Safety of machinery - Electrical equipment of units - Part 1: General requirements.

And exclusively for the model UNI 2 C-W3

UNI EN 21904-1:2020: Safety in Welding - Devices for the capture and separation of welding fumes - Part 1: General requirements

UNI EN 21904-2:2020: Safety in Welding - Devices for the capture and separation of welding fumes - Part 2: Test requirements

The complete list of applied standards, guidelines and specifications are available at the Manufacturer.

Additional information: The declaration of conformity decays in case of non-compliant use and in the event of configuration changes that have not been previously approved by the Manufacturer in writing.

DECLARES THAT THE TECHNICAL FILE

Has been compiled, and is kept and available at the registered office of the Company.

Place and date of the document
 Legnaro,

The Manufacturer
 Marco Gallerino



9.4. Dimensional drawing

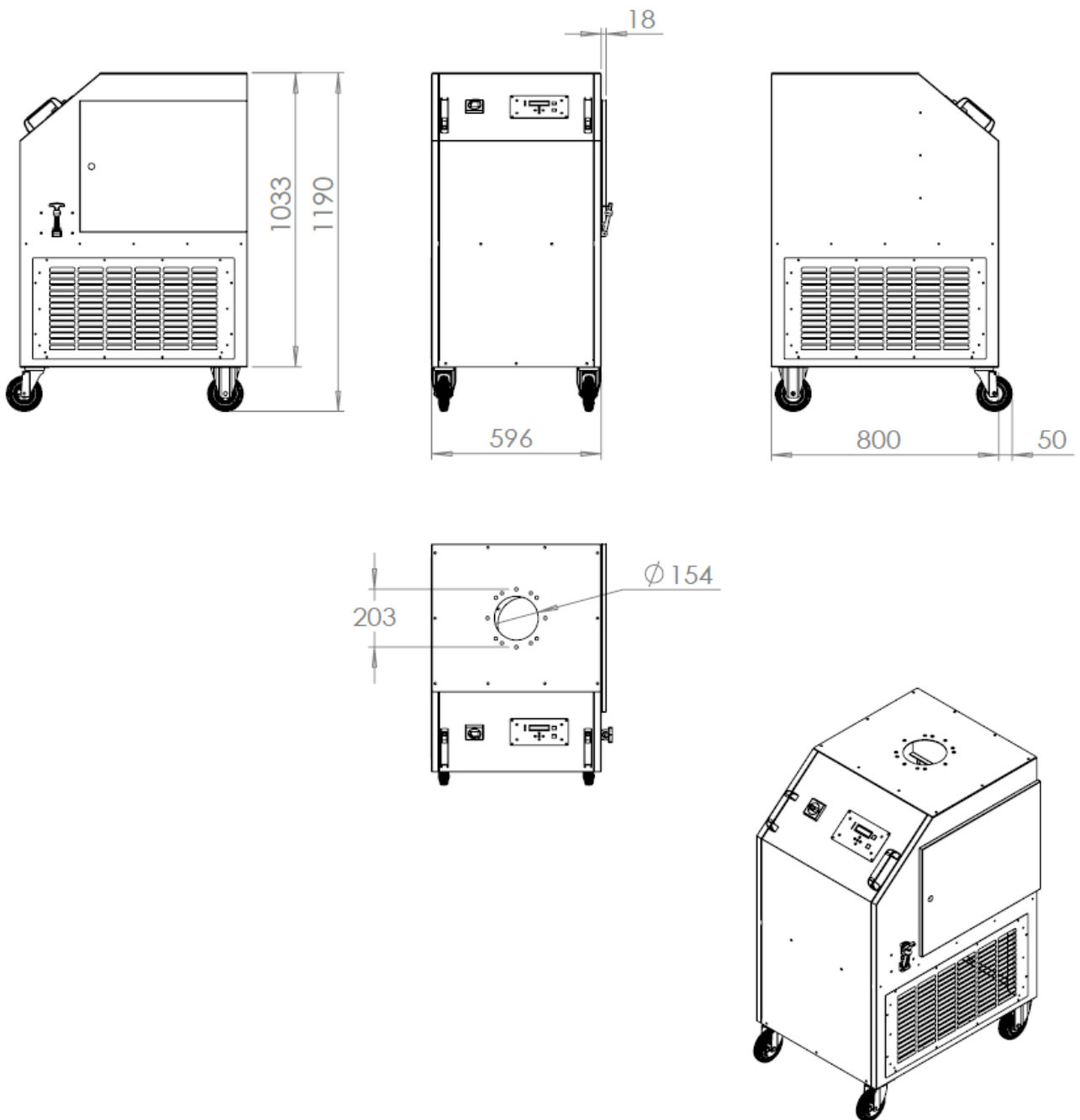

9.5.1. Wiring diagram UNI 2 H/K 230V 1ph

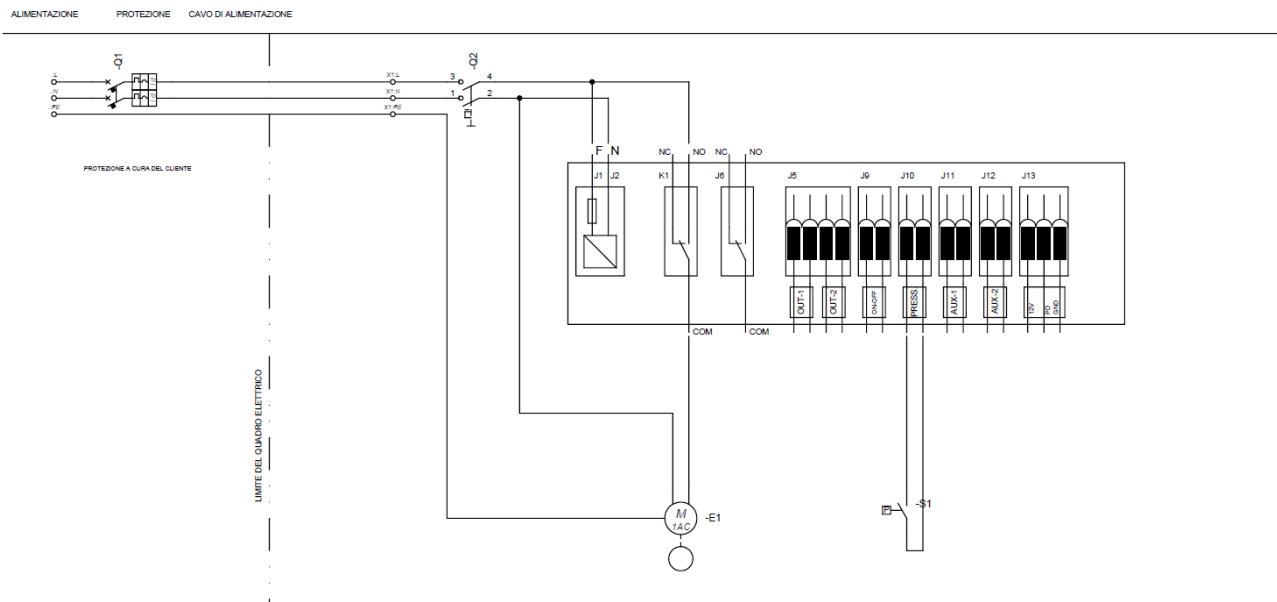

9.5.2 Wiring diagram UNI 2 H/K 400V 3ph

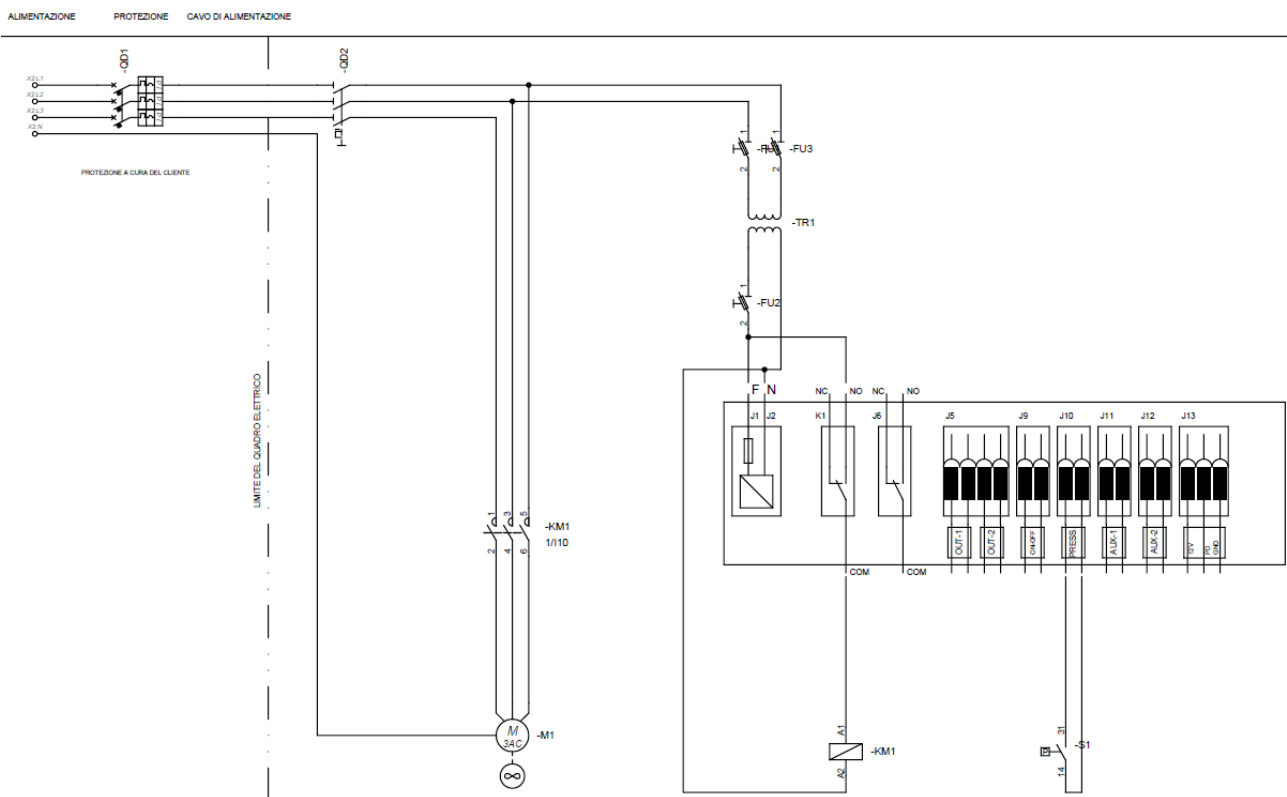

9.5.3 Wiring diagram UNI 2 E 230V 1ph

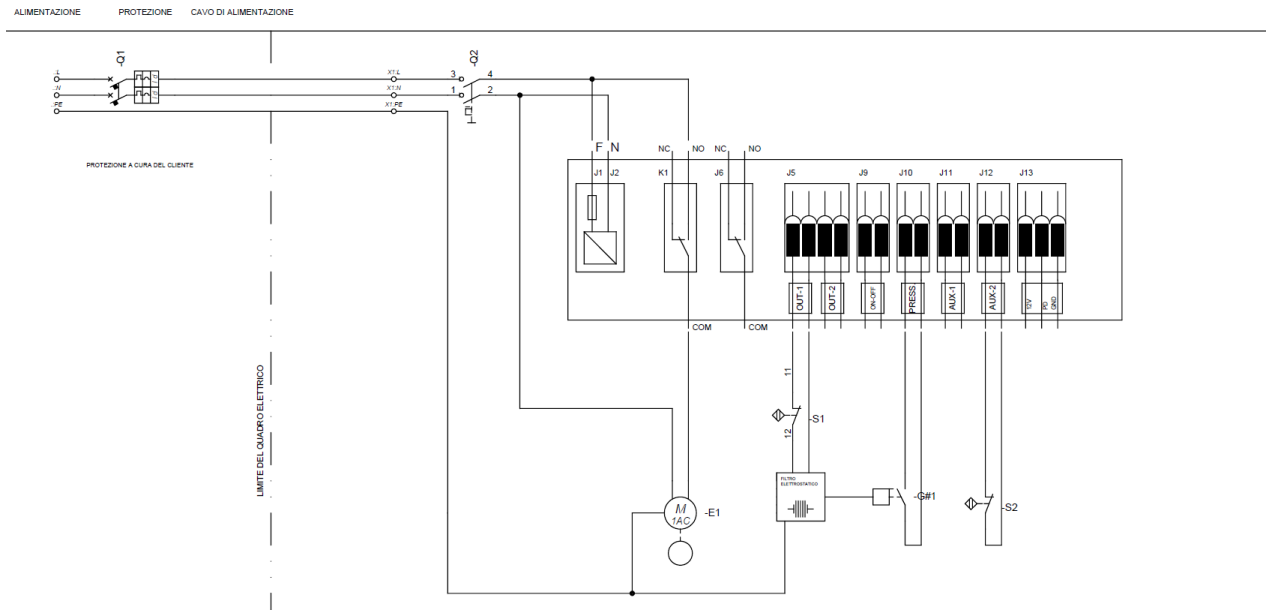

9.5.4 Wiring diagram UNI 2 E 400V 3ph

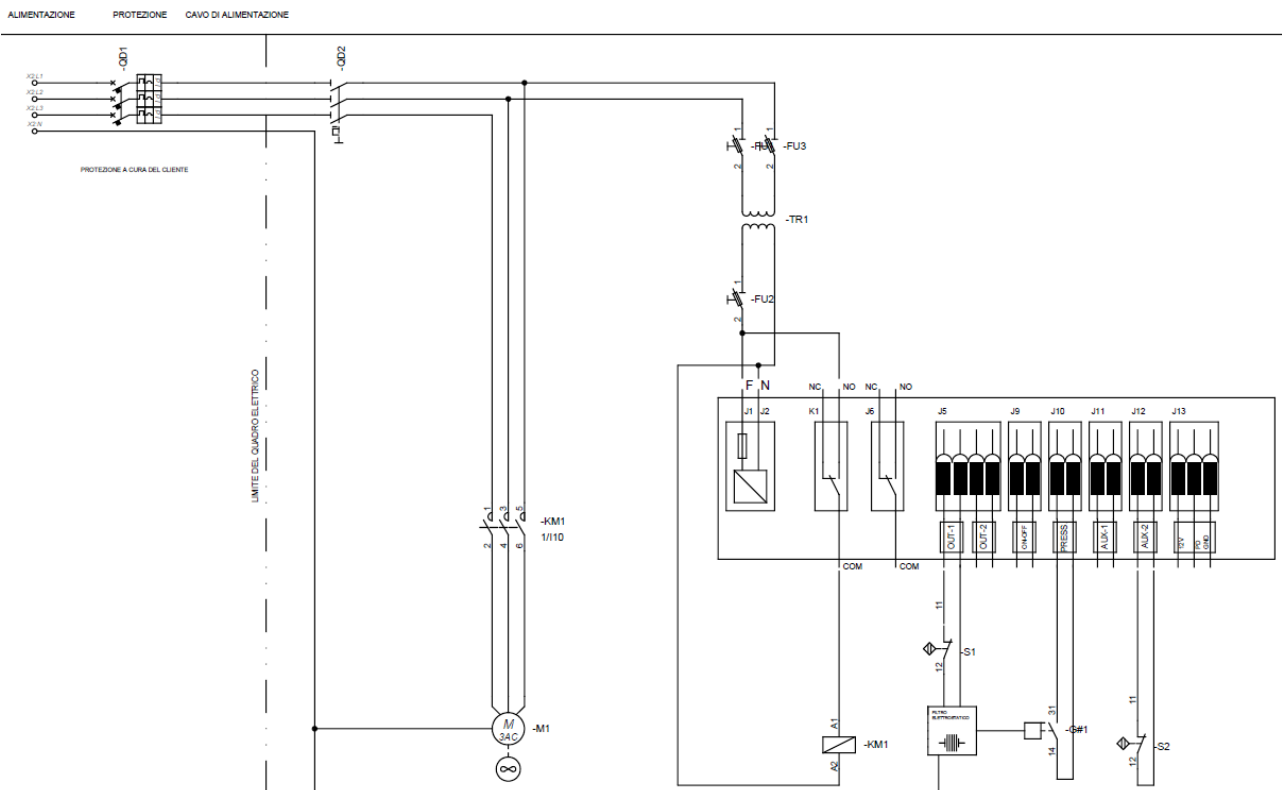

9.5.5 Wiring diagram UNI 2 C 230V 1ph

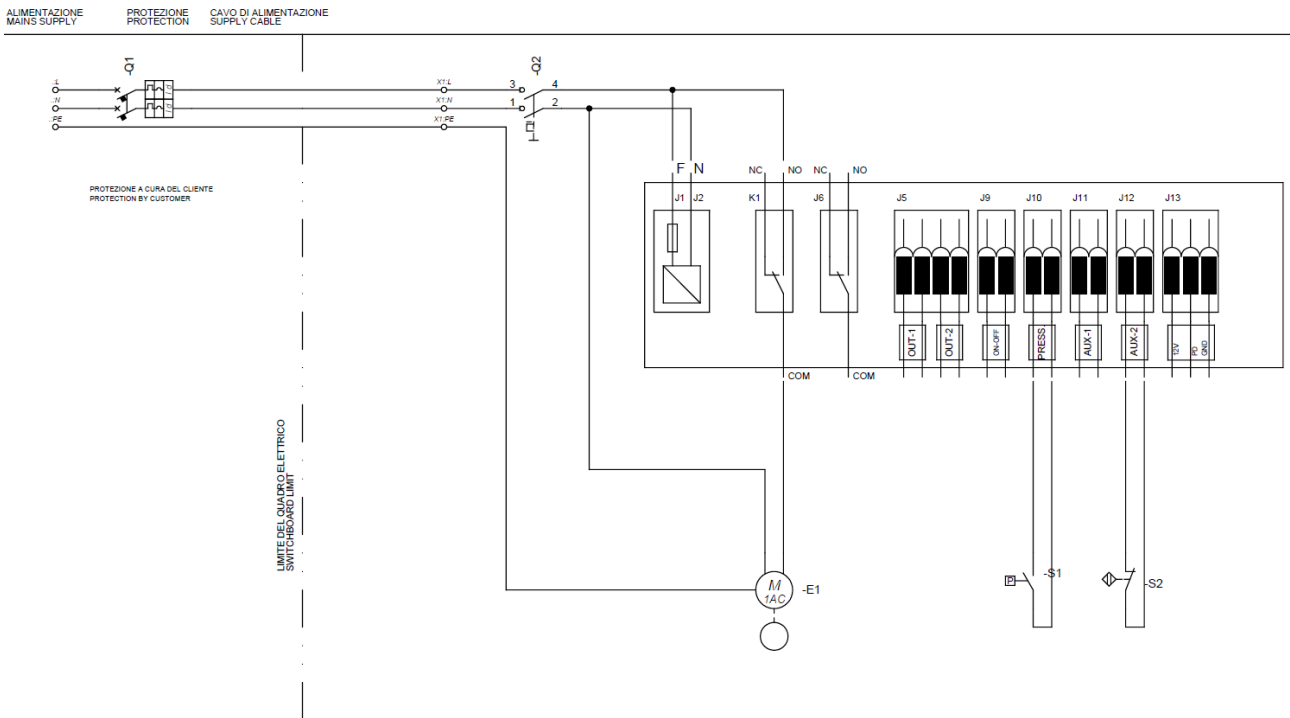

9.5.6 Wiring diagram UNI 2 C 400V 3ph

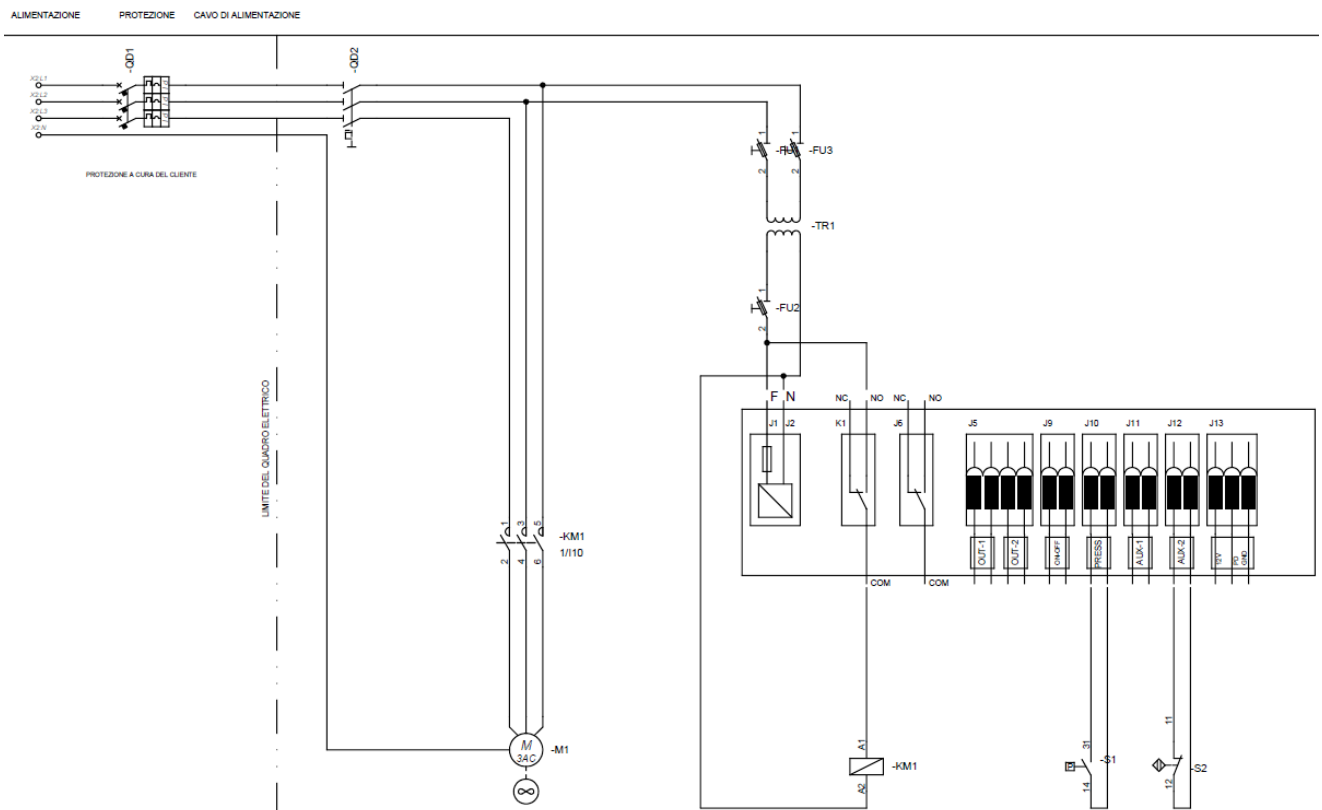

9.5.7 Wiring diagram UNI 2 C-W3 / UNI 2 C-W3 Laser 230V 1ph

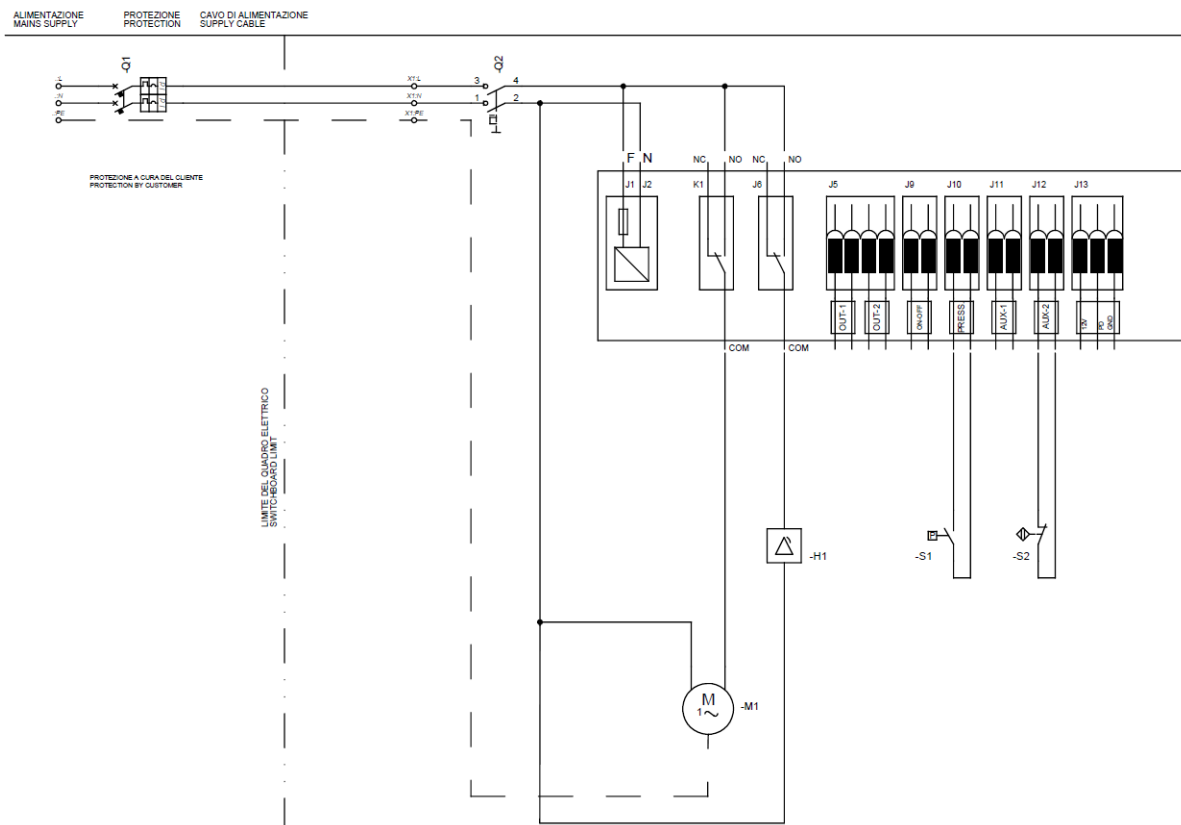

9.5.8 Wiring diagram UNI 2 C-W3 / UNI 2 C-W3 Laser 400V 3ph

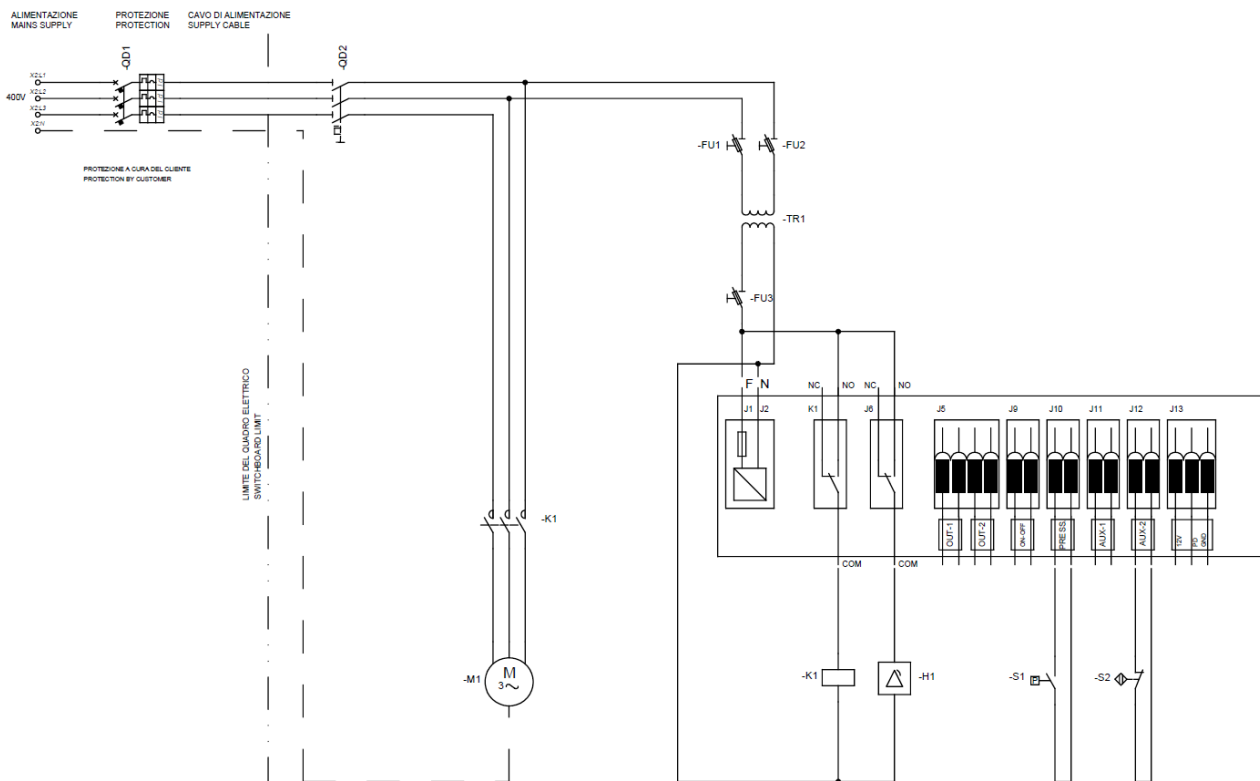



Aerservice Equipments S.r.l.

Viale dell'industria, 24 Z.I.

35020 - Legnaro (PD) Italy

Tel. +39 049 641 200

E-mail: info@aerservice.com

equipments.aerservice.com